

**ENGINEERING
ADMISSIONS ASSESSMENT****D564/11****November 2021****60 minutes****SECTION 1****INSTRUCTIONS TO CANDIDATES**

Please read these instructions carefully, but do not open this question paper until you are told that you may do so. This paper is Section 1 of 2.

A separate answer sheet is provided for this paper. Please check you have one. You also require a soft pencil and an eraser.

Please complete the answer sheet with your candidate number, centre number, date of birth, and name.

At the end of 60 minutes, your supervisor will collect this question paper and answer sheet before giving out Section 2.

This paper contains **two** parts, **A** and **B**, and you should attempt **both** parts.

Part A Mathematics and Physics (20 questions)
Part B Advanced Mathematics and Advanced Physics (20 questions)

You are **strongly** advised to divide your time equally between the two parts: 30 minutes on **Part A** and 30 minutes on **Part B**. The scores for Part A and Part B are reported separately.

This paper contains 40 multiple-choice questions. There are no penalties for incorrect responses, only marks for correct answers, so you should attempt **all** 40 questions. Each question is worth one mark.

For each question, choose the **one** option you consider correct and record your choice on the separate answer sheet. If you make a mistake, erase thoroughly and try again.

You **must** complete the answer sheet within the time limit.

You can use the question paper for rough working, but **no extra paper** is allowed. Only your responses on the answer sheet will be marked.

Dictionaries and calculators are NOT permitted.

Please wait to be told you may begin before turning this page.

This question paper consists of 35 printed pages and 5 blank pages.



BLANK PAGE

PART A Mathematics and Physics

1 Simplify fully

$$5xy^2 \times (5x^2y)^{-3} \times 5x^2y$$

where x and y are positive.

A $\frac{1}{125x^7y^2}$

B $\frac{1}{125x^6y^2}$

C $\frac{1}{25x^6y}$

D $\frac{1}{25x^4y}$

E $\frac{1}{5x^3}$

F $\frac{1}{5x^2}$

G $\frac{y}{x^2}$

H $5xy^2$

- 2 Air is trapped in a cylinder by a piston. The density of the air in the cylinder is ρ .

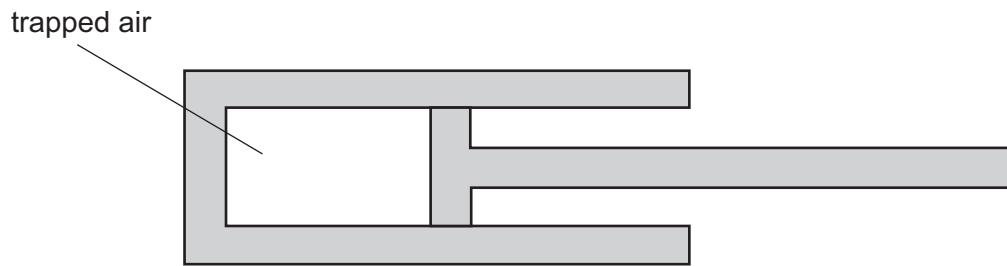

The piston is moved so that the pressure of the trapped air increases by 20%. The temperature of the trapped air does not change.

What is the new density of the trapped air?

(Assume that air is an ideal gas.)

- A 0.69ρ
- B 0.80ρ
- C 0.83ρ
- D 1.00ρ
- E 1.20ρ
- F 1.44ρ

3 Which of the following is a rearrangement of

$$\frac{p}{2} + \frac{3}{q} = \frac{4}{r}$$

so that q is the subject?

A $q = \frac{2r}{24 - 3pr}$

B $q = \frac{3r}{2r - p}$

C $q = \frac{6r}{4 - p}$

D $q = \frac{6r}{8 - pr}$

E $q = \frac{r - 2}{12p}$

F $q = \frac{3r - 6}{4p}$

G $q = \frac{pr - 8}{12p}$

H $q = \frac{3pr - 24}{4p}$

- 4 A **non-ideal** transformer has 100 turns on the primary coil and 25 turns on the secondary coil. It is provided with 3.0 kW of electrical power at a current of 12.5 A. The voltage output is the same as for an ideal transformer, but the current in the output coil is 40 A.

What is the efficiency of the transformer?

- A 20%
- B 25%
- C 31%
- D 69%
- E 75%
- F 80%
- G 91%
- H 100%

- 5 Two solid cylinders, P and Q, are shown, where $x > y$.

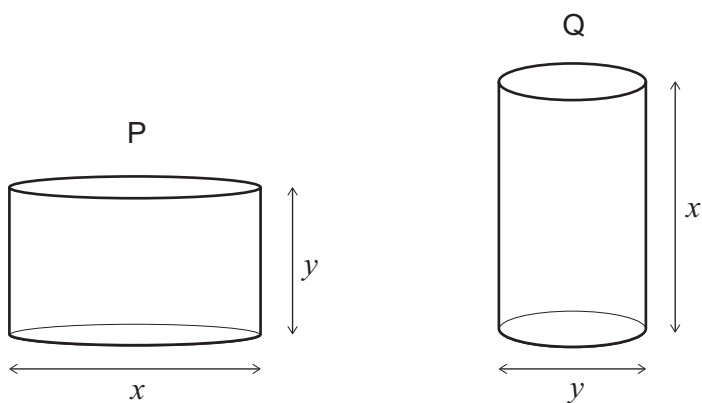

Cylinder P has diameter x and height y .

Cylinder Q has diameter y and height x .

What is the positive difference between the total surface areas of P and Q?

- A 0
- B $\frac{\pi}{4}(x^2 - y^2)$
- C $\frac{\pi}{2}(x^2 - y^2)$
- D $\pi(x^2 - y^2)$
- E $2\pi(x^2 - y^2)$
- F $\frac{\pi}{4}xy(x - y)$
- G $\pi xy(x - y)$

- 6 A light spring has an uncompressed length of 0.10 m. When an object of mass 0.5 kg rests in equilibrium on top of the spring, the length of the spring reduces to 0.08 m as shown.



What is the energy stored in the spring due to the compression?

(gravitational field strength = 10 N kg^{-1} ; the spring obeys Hooke's law)

- A 0.005 J
 B 0.02 J
 C 0.05 J
 D 0.1 J
 E 0.2 J
 F 0.4 J
- 7 The price of item P is reduced by 10%. The next day, the new price is increased by 10%.
 The price of item Q is increased by 10%. The next day, the new price is reduced by 10%.
 How does the final price of each item compare to the original price of that item?

	<i>item P final price</i>	<i>item Q final price</i>
A	lower than original	lower than original
B	lower than original	higher than original
C	higher than original	lower than original
D	higher than original	higher than original
E	the same as original	the same as original

- 8 A set of decorative lights consists of 20 lamps connected in series to a dc supply of constant voltage.

The total power transferred by all the lamps is P .

The set is designed so that if one of the lamps fails, that lamp becomes short-circuited and it then has zero resistance. The remaining lamps are still lit.

If this happens, with the set connected to the same supply, what is the new total power transferred by the remaining 19 lamps?

(Assume that the resistance of each functioning lamp remains constant.)

A $\left(\frac{19}{20}\right)^2 P$

B $\left(\frac{19}{20}\right) P$

C P

D $\left(\frac{20}{19}\right) P$

E $\left(\frac{20}{19}\right)^2 P$

9

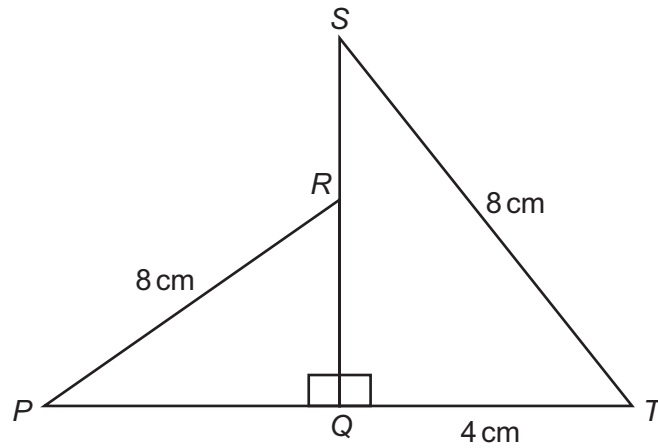

[diagram not to scale]

SQT is a right-angled triangle with the right angle at Q .

The point R is on SQ such that $SR:RQ = 1:3$

QRP is a right-angled triangle with the right angle at Q .

$PR = ST = 8$ cm

$QT = 4$ cm

What is the length of PQ , in cm?

- A $2\sqrt{3}$
- B $4\sqrt{3}$
- C $\sqrt{19}$
- D $\sqrt{37}$
- E $\sqrt{55}$
- F $\sqrt{61}$

10 A train accelerates from rest along a straight, horizontal section of track.

The force exerted on the train due to its motors is constant and there is a constant friction force of $1.8 \times 10^7 \text{ N}$.

The graph shows how the momentum of the train changes with time.

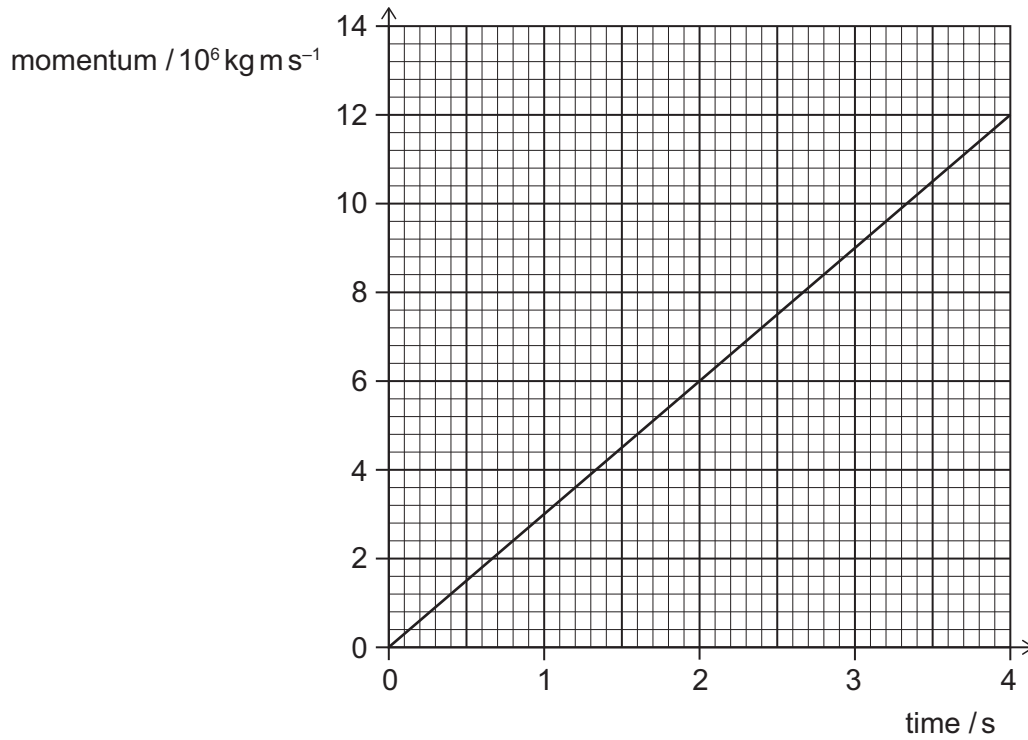

What is the force exerted on the train due to its motors?

- A $3.0 \times 10^6 \text{ N}$
- B $6.0 \times 10^6 \text{ N}$
- C $1.2 \times 10^7 \text{ N}$
- D $1.5 \times 10^7 \text{ N}$
- E $2.1 \times 10^7 \text{ N}$
- F $2.4 \times 10^7 \text{ N}$
- G $3.0 \times 10^7 \text{ N}$
- H $4.2 \times 10^7 \text{ N}$

- 11 The curve with equation $y = x^2 - 4x + 5$ meets the straight line with equation $y = 2x + c$ at two points, which have x -coordinates p and q , where $q > p$.

Given that $q - p = 8$, what is the value of the constant c ?

- A -43
- B -12
- C -2
- D 0
- E 2
- F 12
- G 43

- 12 A ship travels into a wave that is travelling in the opposite direction to the ship.

The ship has a horizontal speed of 8.0 m s^{-1} . The speed of the wave is 3.0 m s^{-1} .

The front of the ship rises and falls with a time period of 8.0 s .

What is the wavelength of the wave?

- A $\frac{3}{8} \text{ m}$
- B $\frac{5}{8} \text{ m}$
- C 1.0 m
- D $\frac{11}{8} \text{ m}$
- E 24 m
- F 40 m
- G 64 m
- H 88 m

13 Given that

$$y = \frac{\sin 60^\circ - 1}{\cos 60^\circ}$$

what is the value of y^3 ?

- A $-\frac{\sqrt{3}}{9}$
- B $-5\sqrt{2} + 10$
- C $3\sqrt{3} - 8$
- D $6\sqrt{3} - 10$
- E $14\sqrt{2} - 20$
- F $15\sqrt{3} - 26$
- G $21\sqrt{3} - 38$

- 14 A 6.0V battery is connected to an 8.0Ω resistor and a filament lamp as shown in the circuit diagram.

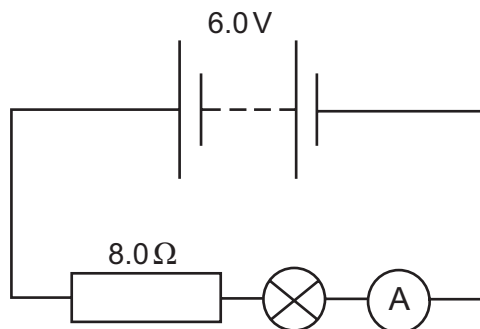

The reading on the ammeter is 0.25A.

Which graph is a possible $V-I$ graph for the filament lamp?

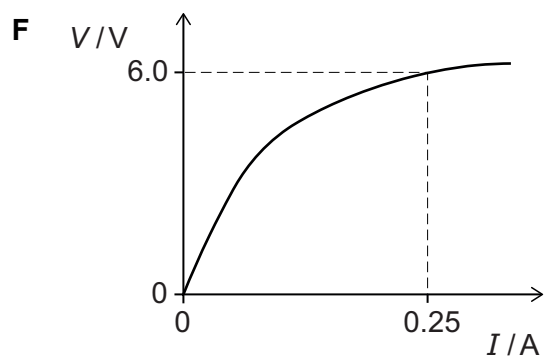
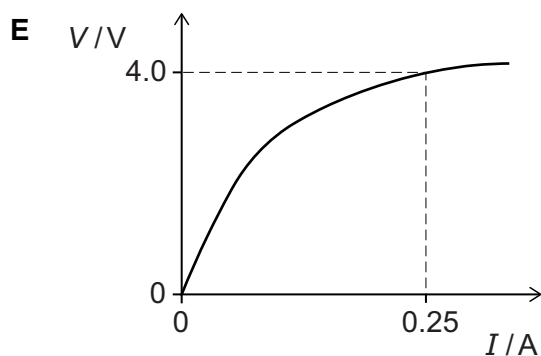
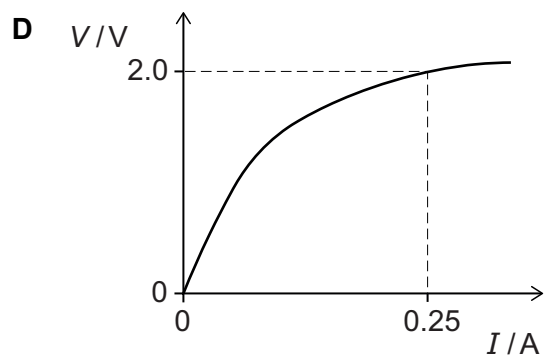
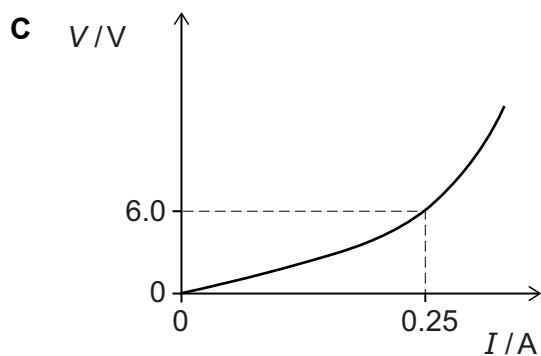
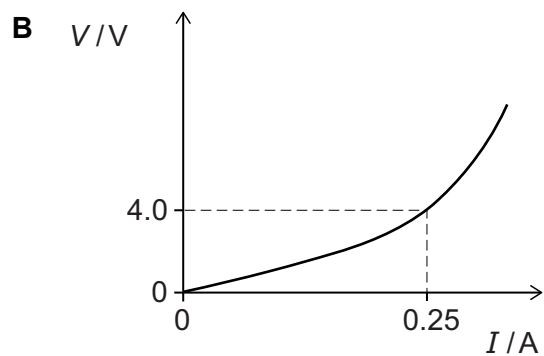
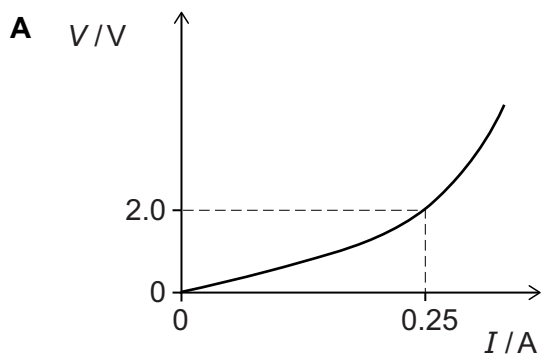

- 15** Charlie has a bowl containing red sweets and green sweets only. The sweets are identical in all respects except colour.

There are nine sweets in total in the bowl.

Charlie eats two sweets from the bowl at random.

The probability of Charlie not eating any green sweets is $\frac{5}{12}$

What is the probability that Charlie eats two green sweets?

A $\frac{2}{27}$

B $\frac{1}{12}$

C $\frac{1}{9}$

D $\frac{4}{27}$

E $\frac{1}{6}$

F $\frac{1}{4}$

G $\frac{7}{12}$

16 A radioactive nuclide X decays in a single stage to a stable nuclide R.

A radioactive nuclide Y decays in a single stage to a stable nuclide S.

When a rock formed it contained equal numbers of atoms of all four nuclides X, Y, R and S.

The half-life of X is T years and the half-life of Y is $2T$ years.

What is the value of $\frac{\text{number of atoms of R}}{\text{number of atoms of S}}$ at a time $4T$ years after the rock has formed?

(Assume that no other processes add or remove X, Y, R or S from the rock during this time.)

A $\frac{1}{4}$

B $\frac{17}{20}$

C $\frac{31}{28}$

D $\frac{6}{5}$

E $\frac{5}{4}$

F 2

- 17 The greatest diagonal distance between the two vertices of a cuboid, as shown in the diagram, is $\sqrt{77}$ cm.

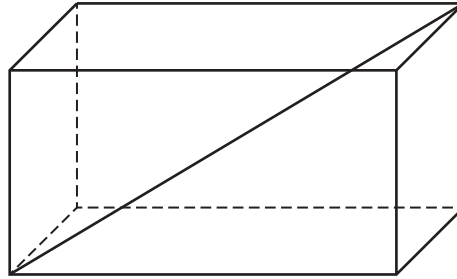

A similar cuboid has all its lengths exactly half the lengths of the original cuboid.

The sides of this smaller cuboid are 2 cm, 3 cm and x cm.

What is the value of x , in cm?

- A $\frac{5}{2}$
- B 5
- C $\frac{5\sqrt{2}}{2}$
- D $5\sqrt{2}$
- E $\frac{\sqrt{102}}{2}$
- F $\sqrt{102}$

18 A beaker containing 180 g of water at 25 °C has a 20 g ice cube at 0 °C added to it.

No heat is transferred between the water and the surroundings (including the beaker).

What is the final temperature of all the water in the beaker after all the ice has melted?

(Take the specific heat capacity of water to be $4 \text{ J g}^{-1} \text{ }^\circ\text{C}^{-1}$ and the specific latent heat of fusion of water to be 300 J g^{-1} .)

A 2.5 °C

B 8.3 °C

C 10.0 °C

D 15.0 °C

E 16.7 °C

F 22.5 °C

19 A car journey is m miles long.

One kilometre is equivalent to x miles.

The car uses one litre of fuel to travel a distance of f kilometres.

Fuel for the car costs p pence per litre.

Which of the following expressions gives the cost of fuel for this journey, in pounds?

(There are 100 pence in one pound.)

A $100fmpx$

B $\frac{100fmp}{x}$

C $\frac{100mpx}{f}$

D $\frac{100mp}{fx}$

E $\frac{fmpx}{100}$

F $\frac{fmp}{100x}$

G $\frac{mpx}{100f}$

H $\frac{mp}{100fx}$

- 20 A pulse of ultrasound travels from one end of a solid uniform rod of length L , starting at time $t = 0$.

The pulse is partially reflected by a crack in the rod and partially by the far end of the rod.

These two reflected pulses travel back along the rod, arriving at the end from which they started at times t_1 and t_2 , where $t_2 > t_1$.

What is the distance between the crack and the **far end** of the rod?

- A $\frac{t_1}{t_2} L$
- B $\frac{t_2}{t_1} L$
- C $\frac{t_1}{2t_2} L$
- D $\frac{t_2}{2t_1} L$
- E $\frac{(t_2 - t_1)}{t_2} L$
- F $\frac{(t_2 - t_1)}{2t_2} L$

BLANK PAGE

PART B Advanced Mathematics and Advanced Physics

21 Given that

$$y = \left(2\sqrt{x} - \frac{1}{2\sqrt{x}} \right)^2$$

find the value of $\frac{dy}{dx}$ when $x = \frac{1}{2}$

- A -12
- B $-\frac{1}{4}$
- C 3
- D $\frac{63}{16}$
- E 5

22 Object P of mass 2.4 kg is on a smooth plane inclined at an angle of 60° to the horizontal. A constant force of magnitude $2F$ parallel to the plane is applied to P. As a result P moves directly up the plane with constant velocity.

Object Q of mass 0.75 kg is on a smooth, horizontal plane. A constant force of magnitude F parallel to the plane is applied to Q. As a result Q moves along the plane with constant acceleration.

What is the acceleration of Q?

(gravitational field strength = 10 N kg^{-1})

- A 4.5 ms^{-2}
- B 6.0 ms^{-2}
- C 8.0 ms^{-2}
- D 16 ms^{-2}
- E $4.5\sqrt{3} \text{ ms}^{-2}$
- F $6.0\sqrt{3} \text{ ms}^{-2}$
- G $8.0\sqrt{3} \text{ ms}^{-2}$
- H $16\sqrt{3} \text{ ms}^{-2}$

23 A particular arithmetic series has first term a and common difference d .

The sum of the first k terms of this series is denoted by S_k

Which of the following is a simplification of $S_{n+1} - S_{n-1}$?

A d

B $2d$

C $2a + d$

D $2a + 2d$

E $2a + nd$

F $2a + 2nd$

G $2a + (2n - 1)d$

H $2a + (4n - 2)d$

- 24 A sound wave is travelling from left to right in air. The diagram represents the wave at a particular instant, and a distance of 33 cm is labelled.

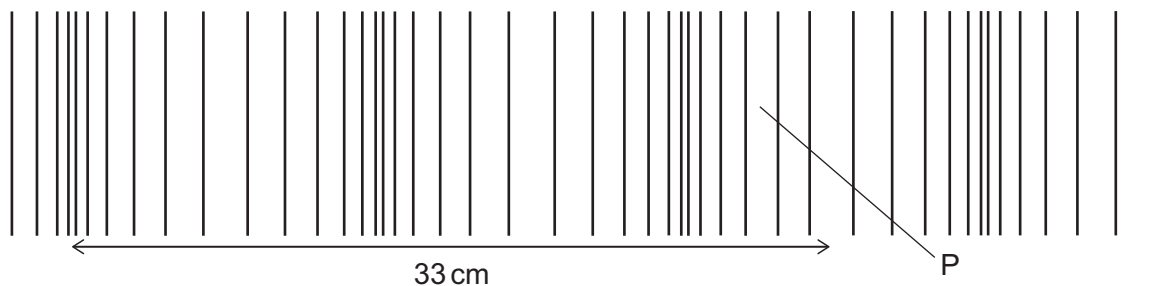

The speed of sound in air is 330 m s^{-1} .

What is the frequency of the sound and in which direction has the air at P been displaced from its mean position?

	<i>frequency of sound / Hz</i>	<i>displacement of air at P</i>
A	1000	to the left
B	2500	to the left
C	5000	to the left
D	1000	to the right
E	2500	to the right
F	5000	to the right

- 25 Find how many distinct real solutions there are to the equation

$$(x^2 + 4x + 3)^2 = 1$$

- A** 0
- B** 1
- C** 2
- D** 3
- E** 4

- 26 A resistor R is connected between terminals X and Y in the circuit shown.

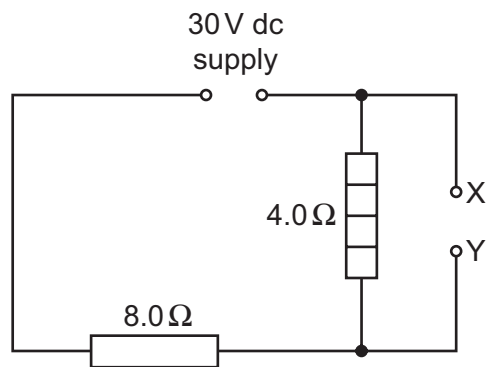

The power transferred in the 4.0Ω heater is 9.0 W .

What is the resistance of R?

- A 1.6Ω
- B 2.0Ω
- C 2.67Ω
- D 4.0Ω
- E 8.0Ω

27 The line $x = 1$ divides the circle $x^2 + y^2 = 4$ into two segments.

What is the area of the smaller segment?

A $\frac{2\pi}{3} - \frac{\sqrt{3}}{2}$

B $\frac{2\pi}{3} - \sqrt{3}$

C $\frac{\pi}{2} - \frac{1}{2}$

D $\frac{\pi}{2} - 1$

E $\pi - \frac{1}{2}$

F $\pi - 1$

G $\frac{4\pi}{3} - \frac{\sqrt{3}}{2}$

H $\frac{4\pi}{3} - \sqrt{3}$

28 A uniform plank of length 5.0 m rests horizontally as shown.

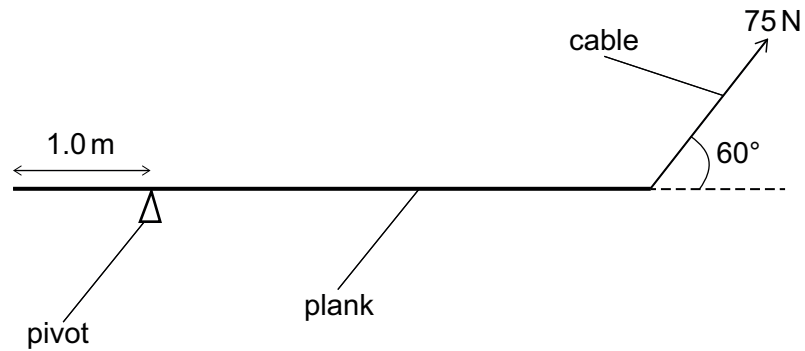

[diagram not to scale]

There is a pivot 1.0 m from one end of the plank.

A cable at an angle of 60° to the horizontal supports the plank at the other end so that it is in equilibrium.

The tension in the cable is 75 N.

What is the weight of the plank?

- A 60 N
- B $60\sqrt{3}$ N
- C 100 N
- D $100\sqrt{3}$ N
- E 125 N
- F $125\sqrt{3}$ N

29 What is the mean of $\log_{10} 27$, $\log_{10} 64$, and $\log_{10} 216$?

A $\frac{\log_{10} 307}{3}$

B $\frac{\log_{10} 81}{3}$

C $\frac{\log_{10} 6^{12}}{3}$

D $\log_{10} 64$

E $\log_{10} 72$

F $\log_{10} 108$

30 A lorry accelerates along a straight, horizontal road with uniform acceleration.

Oil droplets from the lorry fall a small distance onto the road at a constant rate. The time interval between successive drips is t .

The diagram shows four successive oil droplets on the road after the lorry has passed.



The distance between the first two of these droplets is x and the distance between the final two is y .

Which expression gives the acceleration of the lorry?

A $\frac{y-x}{3t^2}$

B $\frac{y-x}{2t^2}$

C $\frac{y-x}{t^2}$

D $\frac{2(y-x)}{t^2}$

E $\frac{y+x}{t^2}$

F $\frac{y+x}{3t^2}$

31 Which of the following is the largest in value?

(All angles are in radians.)

A $\cos 0.5$

B $\cos 0.75$

C $\cos 1$

D $\sin 0.5$

E $\sin 0.75$

F $\sin 1$

32 A light, metal wire of length 2.5 m and cross-sectional area $1.8 \times 10^{-6} \text{ m}^2$ is suspended vertically. A mass of 7.2 kg is attached to the lower end of the wire. The wire extends by 0.50 mm.

What is the Young modulus of the metal and how much energy is stored in the extended wire?

(gravitational field strength = 10 N kg^{-1} ; assume that the wire obeys Hooke's law and that changes in the cross-sectional area are negligible)

	<i>Young modulus / Pa</i>	<i>energy stored / J</i>
A	5.0×10^{-12}	0.018
B	5.0×10^{-12}	0.036
C	2.0×10^{11}	0.018
D	2.0×10^{11}	0.036
E	2.0×10^{14}	18
F	2.0×10^{14}	36

- 33** A geometric progression has first term $u_1 = a$ and common ratio r .

The sum to infinity of the geometric progression is $\frac{8}{5}$

The sum to infinity of the even-numbered terms ($u_2 + u_4 + u_6 + \dots$) is $\frac{3}{5}$

What is the value of $a + r$?

A $\frac{3}{5}$

B $\frac{31}{25}$

C $\frac{23}{5}$

D $\frac{28}{5}$

E $\frac{67}{8}$

- 34** A child of mass 30 kg is on a sledge of mass 10 kg which is moving down a smooth slope at an instantaneous speed of 4.0 m s^{-1} .

At this instant, the child jumps backwards off the sledge and lands stationary on the slope.

What is the speed of the sledge immediately after the child jumps off?

A 4.0 m s^{-1}

B 8.0 m s^{-1}

C 12 m s^{-1}

D 16 m s^{-1}

E 20 m s^{-1}

- 35 At how many distinct points do the following two curves meet?

$$y = (x - 4)(x^2 - 2x - 8)$$

$$y = -x^2 + 8x - 16$$

- A 0
B 1
C 2
D 3
E 4
F 5
- 36 A piece of electrically conducting putty is formed into the shape of a uniform cylinder. The resistance between the ends of the cylinder is R .
- The same piece of putty is now formed into a new uniform cylinder with half the diameter of the first cylinder.
- What is the resistance between the ends of the new cylinder?
- A $\sqrt{2}R$
B $2\sqrt{2}R$
C $4\sqrt{2}R$
D $2R$
E $4R$
F $8R$
G $16R$

37 Evaluate

$$\frac{3}{\sqrt{27} + \sqrt{21}} + \frac{3}{\sqrt{24} + \sqrt{18}} + \frac{3}{\sqrt{21} + \sqrt{15}} + \dots + \frac{3}{\sqrt{9} + \sqrt{3}}$$

A $\frac{3\sqrt{2}}{2}$

B $3\sqrt{2}$

C $\frac{3\sqrt{3}}{2}$

D $\sqrt{3}$

E $1 + \sqrt{2}$

F $3(1 + \sqrt{2})$

G $\frac{\sqrt{3}}{3} \left(1 + \frac{\sqrt{2}}{2} \right)$

H $\sqrt{3} \left(1 + \frac{\sqrt{2}}{2} \right)$

38 A car accelerates from rest in a straight line. During the first 10 s, its acceleration, a , in ms^{-2} is given by the equation

$$a = 4.0 - 0.36t$$

where t is the time in seconds.

What is its displacement from its original position after 10 s?

A 22 m

B 110 m

C 136 m

D 140 m

E 220 m

F 1100 m

G 1360 m

H 1400 m

39

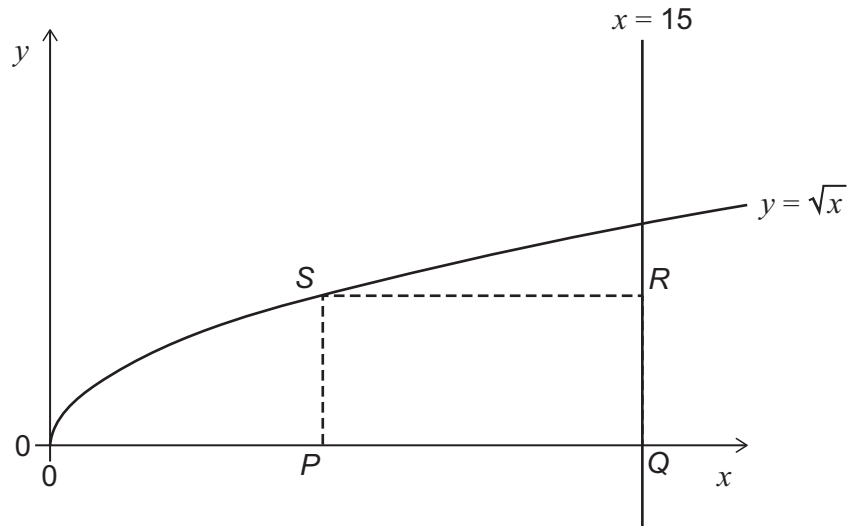

$PQRS$ is a rectangle.

P and Q lie on the x -axis.

Q and R lie on the line $x = 15$

S lies on the curve $y = \sqrt{x}$

What is the maximum possible area of the rectangle?

- A $5\sqrt{5}$
- B $10\sqrt{5}$
- C 50
- D $25\sqrt{5}$
- E 100
- F 125

- 40** Two trolleys are free to move on a smooth one-dimensional track. A light spring is compressed between the two stationary trolleys, the trolleys are released and then separate.

The trolleys have masses m and $4m$ and the work done by the spring as it expands is W . Assume that no work is done against frictional forces.

What is the difference in kinetic energy between the two trolleys when the spring has expanded?

- A** 0
- B** $\frac{W}{5}$
- C** $\frac{W}{4}$
- D** $\frac{W}{2}$
- E** $\frac{3W}{5}$
- F** $\frac{3W}{4}$
- G** $\frac{4W}{5}$
- H** W

END OF TEST

BLANK PAGE

BLANK PAGE

BLANK PAGE



ENGINEERING
ADMISSIONS ASSESSMENT

D564/12

November 2021

60 minutes

SECTION 2

INSTRUCTIONS TO CANDIDATES

Please read these instructions carefully, but do not open this question paper until you are told that you may do so. This paper is Section 2 of 2.

A separate answer sheet is provided for this paper. Please check you have one. You also require a soft pencil and an eraser.

Please complete the answer sheet with your candidate number, centre number, date of birth, and name.

This paper contains 20 multiple-choice questions. There are no penalties for incorrect responses, only marks for correct answers, so you should attempt **all** 20 questions. Each question is worth one mark.

For each question, choose the **one** option you consider correct and record your choice on the separate answer sheet. If you make a mistake, erase thoroughly and try again.

You **must** complete the answer sheet within the time limit.

You can use the question paper for rough working, but **no extra paper** is allowed. Only your responses on the answer sheet will be marked.

Dictionaries and calculators are NOT permitted.

Please wait to be told you may begin before turning this page.

This question paper consists of 22 printed pages and 2 blank pages.



BLANK PAGE

- 1 Two loudspeakers are positioned 8.0 m apart as shown.

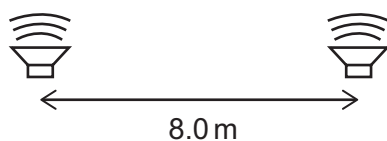

The loudspeakers emit sound waves of the same single frequency. The wave emitted by one loudspeaker is 180° out of phase with the wave emitted by the other loudspeaker.

A point P is in front of the loudspeakers. P is 18.0 m from one loudspeaker and 24.0 m from the other loudspeaker. As a result of superposition of the two waves arriving at P, the amplitude of the sound at position P is a minimum.

The speed of the sound is 336 m s^{-1} .

What is the lowest possible frequency of the sound?

- A 21 Hz
- B 28 Hz
- C 42 Hz
- D 56 Hz
- E 63 Hz
- F 84 Hz

2 A block is at rest on a rough inclined plane.

The acute angle between the plane and the horizontal is greater than 45° .

The forces acting on the block are: friction (F), weight (W) and normal contact force (N).

How do the magnitudes of the three forces compare?

A $F < N < W$

B $F < W < N$

C $N < F < W$

D $N < W < F$

E $W < F < N$

F $W < N < F$

- 3** A dc power supply, a resistor of constant resistance $50\ \Omega$ and a piece of resistance wire are connected in series.

The length of the resistance wire is 20 m and its cross-sectional area is $0.10\ \text{mm}^2$. The wire is made from a material with resistivity $1.0 \times 10^{-7}\ \Omega\ \text{m}$ and the current in it is 200 mA.

What is the voltage across the terminals of the power supply?

- A** 4.0V
- B** 6.0V
- C** 9.9V
- D** 10.0V
- E** 10.1V
- F** 12.0V
- G** 14.0V

- 4 Two objects of mass M and m are connected by a rope over a pulley on an inclined plane as shown.

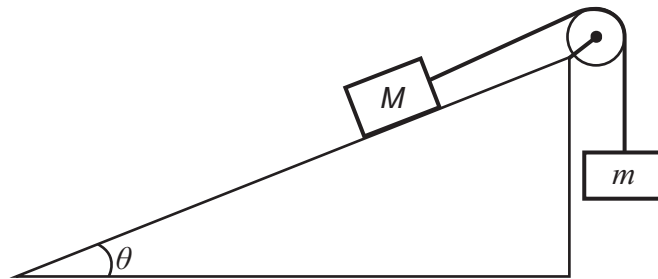

[diagram not to scale]

There is no friction between the plane and the object. The pulley is smooth, and the rope has negligible mass.

The angle θ of the plane to the horizontal is such that $\sin \theta = 0.80$ and $\cos \theta = 0.60$.

The object with mass M accelerates down the slope.

Which expression describes the full range of possible values of M compared with m ?

- A $M > \frac{3}{5}m$
- B $M > \frac{4}{5}m$
- C $M > m$
- D $M > \frac{5}{4}m$
- E $M > \frac{5}{3}m$

5 An object P falls vertically from rest through air and reaches terminal velocity.

An identical object Q is projected vertically upwards from the ground.

When Q reaches its maximum height, P collides with it. The two objects join together in such a way that there is no change to the area of cross section passing through the air.

The two combined objects then fall through the air as one object.

Which sketch graph shows the variation of velocity with time for object P before and after the collision?

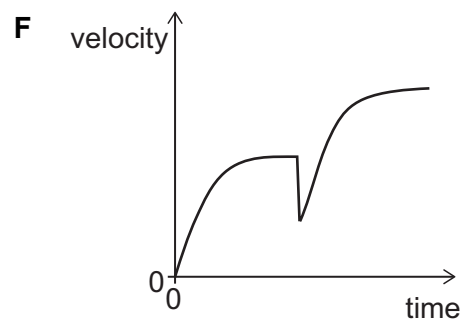
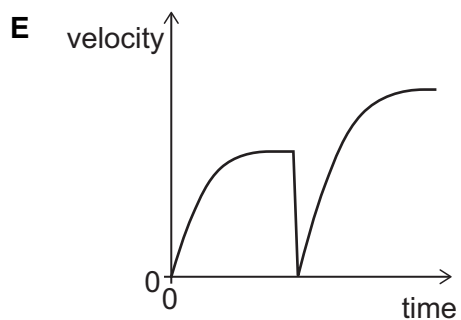
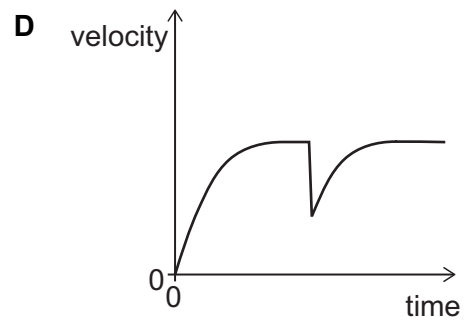
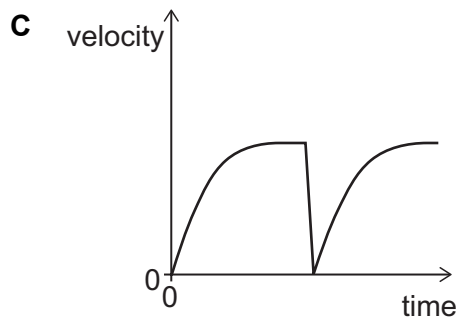
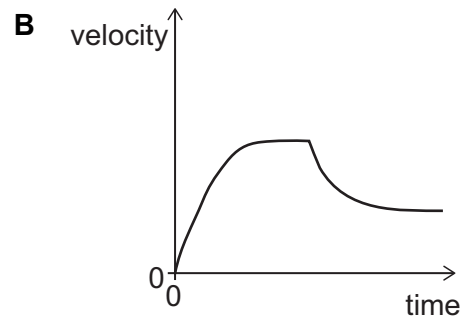
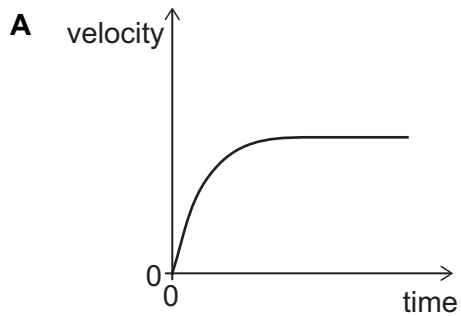

6 A lorry of mass m has an engine that develops a constant mechanical output power P .

The lorry is accelerated from rest by the engine in a horizontal straight line. The lorry experiences a total resistive force that is always proportional to the square of its speed.

The process is repeated for different values of P , and the maximum speed of the lorry is found to be proportional to P^n , where n is a constant.

What is the value of n ?

A $\frac{1}{3}$

B $\frac{1}{2}$

C 1

D 2

E 3

- 7 A battery pack consists of 6 cells, each with an emf of 1.50 V and each with an internal resistance of $0.20\ \Omega$.

The cells are arranged in two rows connected in parallel. Each row contains 3 cells connected in series.

The battery pack is connected to an external resistor of resistance $1.20\ \Omega$.

What is the electrical power transferred in the external resistor?

- A 2.7 W
- B 3.6 W
- C 7.5 W
- D 10.8 W
- E 13.5 W
- F 43.2 W

- 8 A light spring is used to support a uniform rod horizontally against a wall as shown. The angle between the spring and the rod is θ .

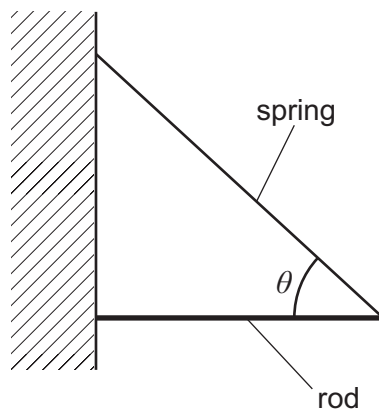

The spring constant of the spring is 20 N m^{-1} and the weight of the rod is 16 N .

The angle θ is such that $\cos \theta = \frac{3}{5}$ and $\sin \theta = \frac{4}{5}$.

How much energy is stored in the spring?

- A 1.6 J
- B 2.5 J
- C 3.2 J
- D 4.4 J
- E 5.0 J
- F 6.4 J
- G 10 J
- H 40 J

- 9** An object of mass 2.0 kg moves in a straight line under the action of a resultant force. The displacement x of the object from its position at time $t = 0$ is given by

$$x = 4.0t^3$$

where x is in metres and t is in seconds.

At $t = 5.0$ s, what is the rate of change of momentum of the object?

- A** 6.7 kg m s^{-2}
- B** 66.7 kg m s^{-2}
- C** 120 kg m s^{-2}
- D** 240 kg m s^{-2}
- E** 600 kg m s^{-2}

- 10** In an industrial process to test the purity of a metal, a narrow beam of ultrasound passes into a block of the metal. The ultrasound generator U is immersed in a gel that is in contact with the metal. The ultrasound passes from the gel into the metal.

The arcs of circles shown in the gel are lines that represent the positions of the compressions (known as wavefronts) of the ultrasound wave that comes from U.

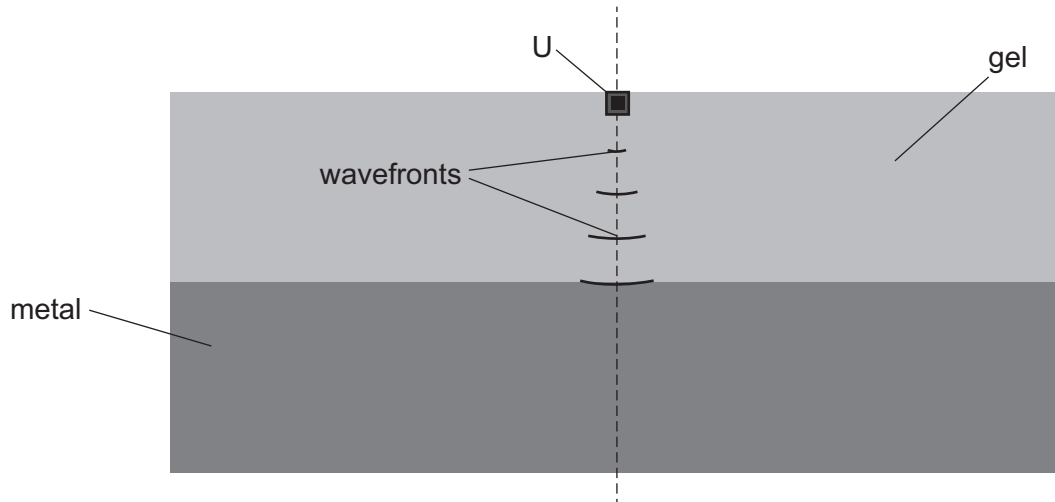

Ultrasound travels faster in the metal than in the gel.

The wavefronts in the metal are circular arcs with their centre at a point X that is on the dashed line.

Where on the dashed line is X?

- A** above U
- B** at U
- C** in the gel below U
- D** on the boundary between the gel and the metal
- E** in the metal

- 11 The diagram shows a circuit containing two power supplies with negligible internal resistance and two resistors with resistances R and $5R$.

The emfs of the power supplies and the magnitude and direction of the current in one part of the circuit are shown.

One point in the circuit is labelled P.

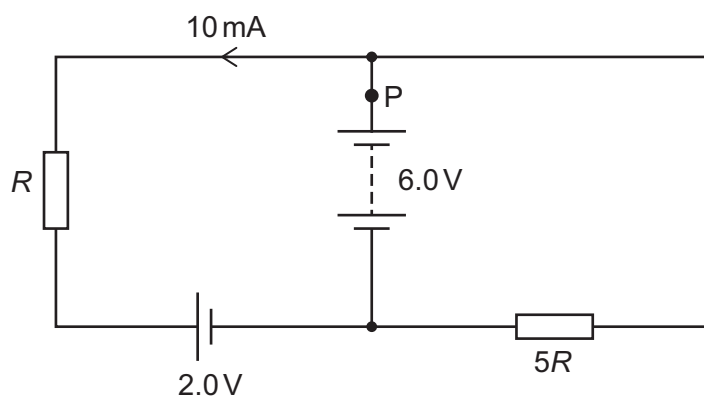

What is the magnitude of the current at P?

- A 3.0 mA
- B 7.0 mA
- C 8.5 mA
- D 11.5 mA
- E 13 mA
- F 25 mA

- 12 A selection of five wires made from the same metal have different unstretched lengths but equal masses. The wires are all subjected to the same small tension force and each wire extends within its limit of proportionality.

Which graph shows the relationship between the extension of the wires and the unstretched length of the wires?

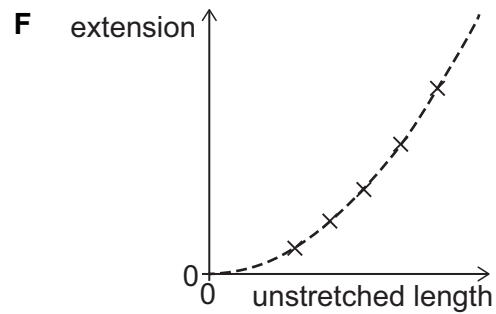
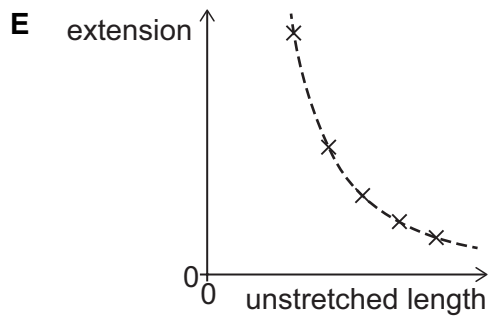
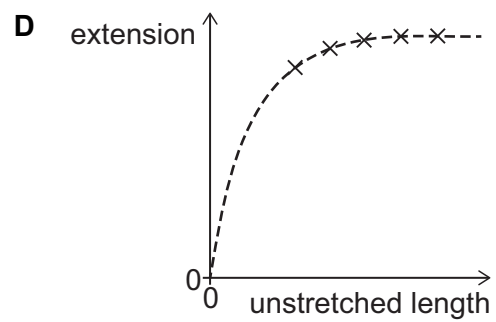
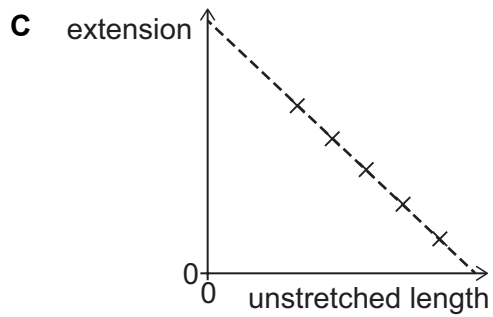
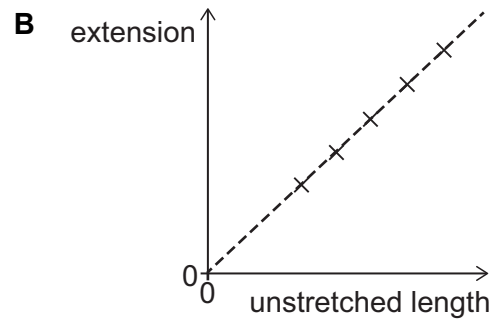
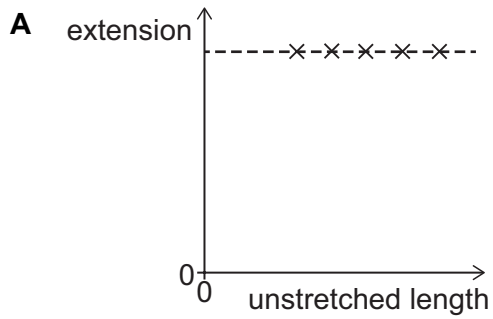

- 13 Water enters a horizontal pipe of cross-sectional area 0.0040 m^2 at constant speed 0.50 m s^{-1} . At the end of the pipe the cross-sectional area reduces to 0.0020 m^2 and the water leaves the pipe as shown. The density of water is 1000 kg m^{-3} .

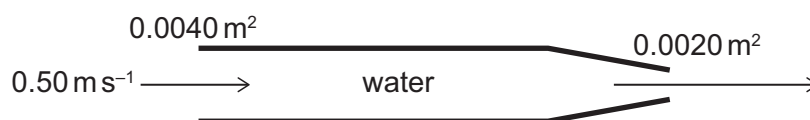

How much power must be supplied to the water to maintain the flow in this section of the pipe?

(Assume that the water is incompressible and that frictional forces can be neglected.)

- A 0.25 W
- B 0.50 W
- C 0.75 W
- D 1.0 W
- E 1.25 W
- F 1.5 W
- G 3.75 W

- 14 Two light wires P and Q support a load of weight W in equilibrium as shown. Wire P is horizontal and wire Q is at an angle of 60° to the vertical. The wires are made from the same material.

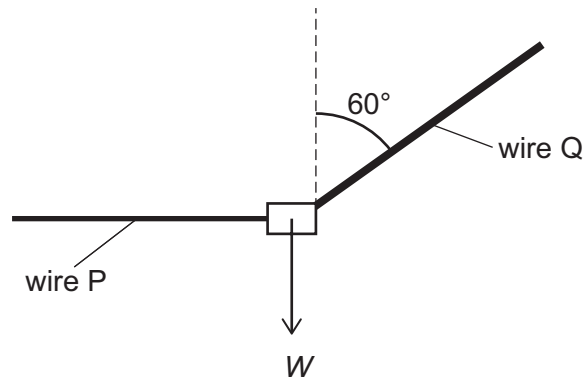

The radius of wire Q is twice the radius of wire P.

What is the ratio

$$\frac{\text{strain in wire P}}{\text{strain in wire Q}} ?$$

(The wires do not exceed their limits of proportionality.)

- A $\frac{\sqrt{3}}{8}$
- B $\frac{\sqrt{3}}{4}$
- C $\frac{\sqrt{3}}{2}$
- D $\sqrt{3}$
- E $2\sqrt{3}$
- F $\frac{4}{\sqrt{3}}$
- G $\frac{8}{\sqrt{3}}$

- 15 The speed of light in a block of glass is $2.0 \times 10^8 \text{ m s}^{-1}$. The block of glass is immersed in a liquid of refractive index 1.2.

The diagram shows a ray of light travelling in the glass block striking the side of the block at the point labelled X. The acute angle between the ray and the side of the block is θ .

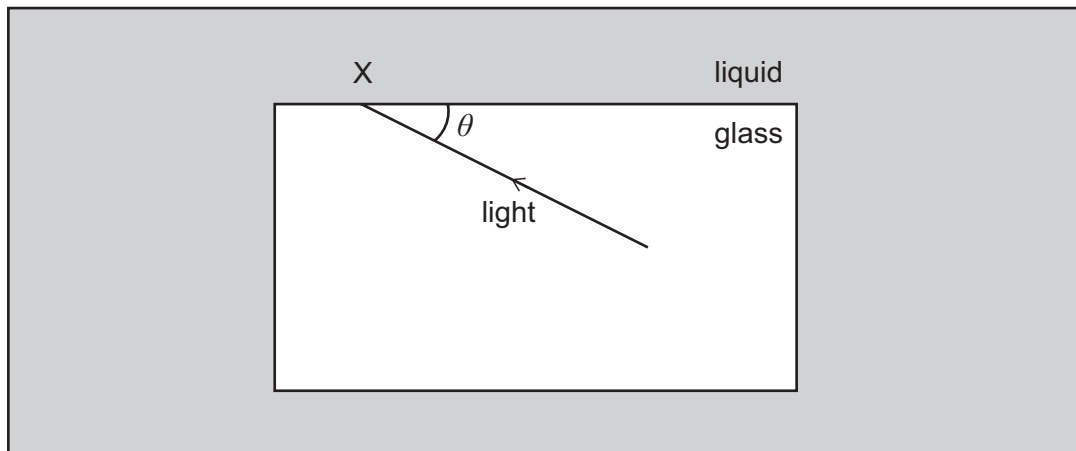

What is the full range of values of the acute angle θ for which light is refracted at X?

(The speed of light in a vacuum is $3.0 \times 10^8 \text{ m s}^{-1}$.)

- A $0^\circ < \theta < \cos^{-1}\left(\frac{2}{3}\right)$
- B $0^\circ < \theta < \cos^{-1}\left(\frac{\sqrt{5}}{3}\right)$
- C $0^\circ < \theta < \cos^{-1}\left(\frac{3}{5}\right)$
- D $0^\circ < \theta < \cos^{-1}\left(\frac{4}{5}\right)$
- E $\cos^{-1}\left(\frac{2}{3}\right) < \theta < 90^\circ$
- F $\cos^{-1}\left(\frac{\sqrt{5}}{3}\right) < \theta < 90^\circ$
- G $\cos^{-1}\left(\frac{3}{5}\right) < \theta < 90^\circ$
- H $\cos^{-1}\left(\frac{4}{5}\right) < \theta < 90^\circ$

- 16 A car is at rest on a straight horizontal road. At time $t = 0$ s the car starts to move along the road. The graph shows how its acceleration varies from $t = 0$ s to $t = 20$ s.

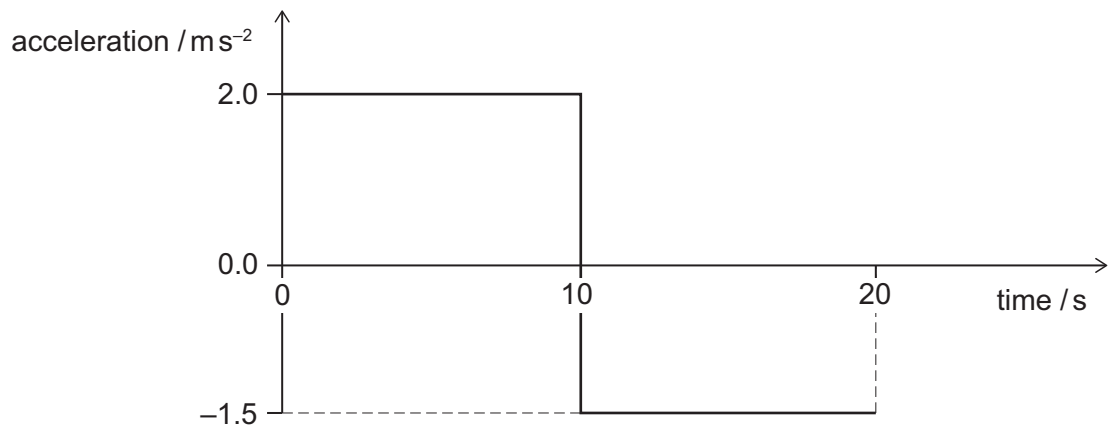

What is the displacement of the car from its starting position when $t = 20$ s?

- A 5.0 m
- B 25 m
- C 35 m
- D 175 m
- E 225 m
- F 375 m

- 17 An empty measuring cylinder is placed on a balance, and the balance reading is then set to zero.

A mass of 8.7 g of a powder is poured into the measuring cylinder as shown in the diagram.

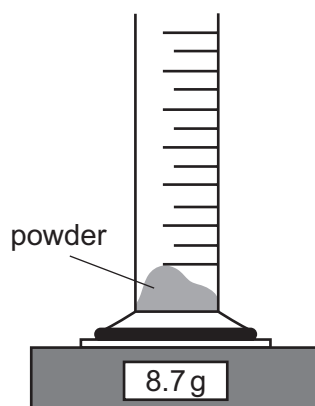

Liquid is poured into the cylinder to cover the powder completely. The powder does not dissolve. The reading on the measuring cylinder and the reading on the balance are recorded.

More liquid is added and a second pair of readings is recorded.

The table shows the two pairs of readings.

<i>reading on measuring cylinder / cm³</i>	<i>reading on balance / g</i>
10.0	15.0
25.0	27.6

What is the density of the material from which the powder is made?

- A 0.414 g cm⁻³
- B 1.16 g cm⁻³
- C 1.31 g cm⁻³
- D 1.45 g cm⁻³
- E 2.00 g cm⁻³
- F 2.50 g cm⁻³
- G 3.48 g cm⁻³
- H 6.00 g cm⁻³

- 18** A stone of mass 100 g is fired horizontally from an 80 m high vertical cliff. The ground below the cliff is horizontal.

The kinetic energy of the stone when it hits the ground is 125 J.

What is the distance from the bottom of the cliff to the point where the stone hits the ground?

(gravitational field strength = 10 N kg^{-1} ; ignore air resistance and any effect of wind)

- A** 60 m
- B** 80 m
- C** 120 m
- D** 160 m
- E** 200 m

- 19 An electrical component is connected to a switch and a power supply which has a constant terminal potential difference V . The switch is initially open. At time $t = 0$ the switch is closed.

When the switch is closed, the current I in the component increases with time t as given by the equation

$$I = kt^2$$

where k is a positive constant.

When the current reaches a value I_F the component fails and the current falls instantly to zero.

How much electrical energy has been transferred to the component by the time it fails?

(All quantities are in standard SI units.)

A $\frac{Vk}{3} \left(\frac{I_F}{k} \right)^{\frac{3}{2}}$

B $Vk \left(\frac{I_F}{k} \right)^{\frac{3}{2}}$

C $3Vk \left(\frac{I_F}{k} \right)^{\frac{3}{2}}$

D $\frac{Vk}{3} \left(\frac{I_F}{k} \right)$

E $Vk \left(\frac{I_F}{k} \right)$

F $3Vk \left(\frac{I_F}{k} \right)$

- 20 A water trough has the shape of a prism, with a cross section that is a right-angled isosceles triangle.

One rectangular face and the two triangular ends of the trough are vertical, as shown.

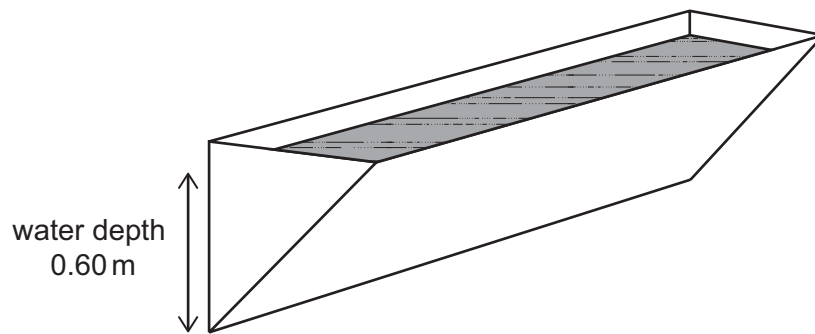

[diagram not to scale]

The trough contains water of depth 0.60 m measured on the vertical rectangular face.

What is the force exerted by the water on one triangular end of the trough?

(density of water = 1000 kg m^{-3} ; gravitational field strength = 10 N kg^{-1})

- A 180 N
- B 270 N
- C 360 N
- D 540 N
- E 720 N
- F 1080 N
- G 6000 N
- H 12000 N

END OF TEST

BLANK PAGE



ENGAA Section 1 Answer Key

TZ1	Answer_key
Q1	E
Q2	E
Q3	D
Q4	F
Q5	C
Q6	C
Q7	A
Q8	D
Q9	D
Q10	E
Q11	F
Q12	H
Q13	F
Q14	B
Q15	B
Q16	C
Q17	A
Q18	D
Q19	H
Q20	E
Q21	C
Q22	G
Q23	G
Q24	B
Q25	D
Q26	D
Q27	H
Q28	D
Q29	E
Q30	B
Q31	A
Q32	C
Q33	B
Q34	D
Q35	C
Q36	G
Q37	H
Q38	D
Q39	B
Q40	E

ENGAA Section 2 Answer Key

TZ1	Answer_key
Q1	D
Q2	C
Q3	G
Q4	D
Q5	F
Q6	A
Q7	D
Q8	B
Q9	D
Q10	C
Q11	E
Q12	F
Q13	C
Q14	E
Q15	H
Q16	E
Q17	G
Q18	C
Q19	A
Q20	C