

**ECONOMICS
ADMISSIONS ASSESSMENT****D563/11****Wednesday 30 October 2019****80 minutes****SECTION 1****INSTRUCTIONS TO CANDIDATES**

Please read these instructions carefully, but do not open this question paper until you are told that you may do so. This paper is Section 1 of 2.

A separate answer sheet is provided for this paper. Please check you have one. You also require a soft pencil and an eraser.

Please complete the answer sheet with your candidate number, centre number, date of birth, and name.

At the end of 80 minutes, your supervisor will collect this question paper and answer sheet before giving out Section 2.

This paper contains **two** parts: **A** and **B**.

Part A Problem Solving (20 questions)
Part B Advanced Mathematics (16 questions)

You should attempt **both** parts and you are **strongly** advised to divide your time equally between the two parts: 40 minutes on **Part A** and 40 minutes on **Part B**.

This paper contains 36 multiple-choice questions. There are no penalties for incorrect responses, only marks for correct answers, so you should attempt **all** 36 questions. Each question is worth one mark.

For each question, choose the **one** option you consider correct and record your choice on the separate answer sheet. If you make a mistake, erase thoroughly and try again.

You **must** complete the answer sheet within the time limit.

You can use the question paper for rough working, but **no extra paper** is allowed. Only your responses on the answer sheet will be marked.

Dictionaries and calculators are NOT permitted.

Please wait to be told you may begin before turning this page.

This question paper consists of 31 printed pages and 1 blank page.



BLANK PAGE

PART A Problem Solving

- 1 Each region in the country of Bolandia sets its own tax rate which applies to the whole of an individual's annual income.

Below is a table showing tax information relating to six different people.

<i>name</i>	<i>region</i>	<i>annual income</i>	<i>tax rate</i>
Tim	North	\$10 000	30%
Neil	Central	\$20 000	25%
Veronica	West	\$150 000	3%
David	North West	\$50 000	6%
Amy	East	\$80 000	5%
Roz	Frontier	\$12 000	30%

Who pays the same amount of tax in a year as Tim?

- A Neil
- B Veronica
- C David
- D Amy
- E Roz

- 2 Below is a greyscale image of the flag of Canada. The flag consists of two red strips on the left and the right, a white square in the middle, and a red maple leaf in the centre.

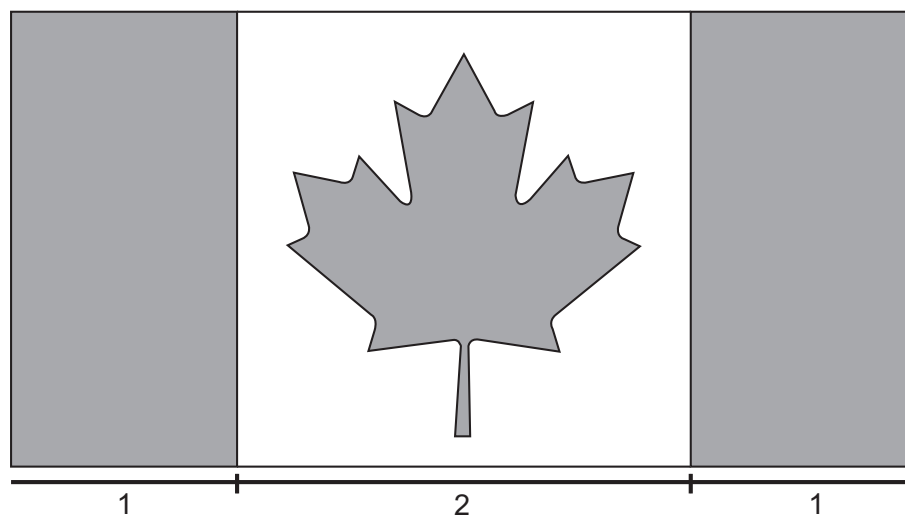

[diagram not to scale]

The width of the white square is twice as large as the width of a red strip. The red maple leaf occupies a quarter of the square in the middle.

What is the ratio of red to white in the flag?

- A 1:1
- B 2:1
- C 3:2
- D 5:3
- E 5:4

- 3 The following table compares five selected commuting routes in different European countries with respect to the length of the journey and the monthly cost of a season ticket as a percentage of average monthly wages.

comparison of selected commuting routes			
<i>journey</i>	<i>country</i>	<i>length (km)</i>	<i>cost as a percentage of average monthly wages</i>
Luton–London	UK	56	14
Brandenburg–Berlin	Germany	69	8
Karis–Helsinki	Finland	75	6
Uppsala–Stockholm	Sweden	72	6
Drogheda–Dublin	Ireland	46	5

On average, the commuters of which route spend the lowest proportion of their wages per kilometre of the route?

- A Luton–London
- B Brandenburg–Berlin
- C Karis–Helsinki
- D Uppsala–Stockholm
- E Drogheda–Dublin

- 4 The bar chart shows the total numbers of tickets sold for a concert over three nights.

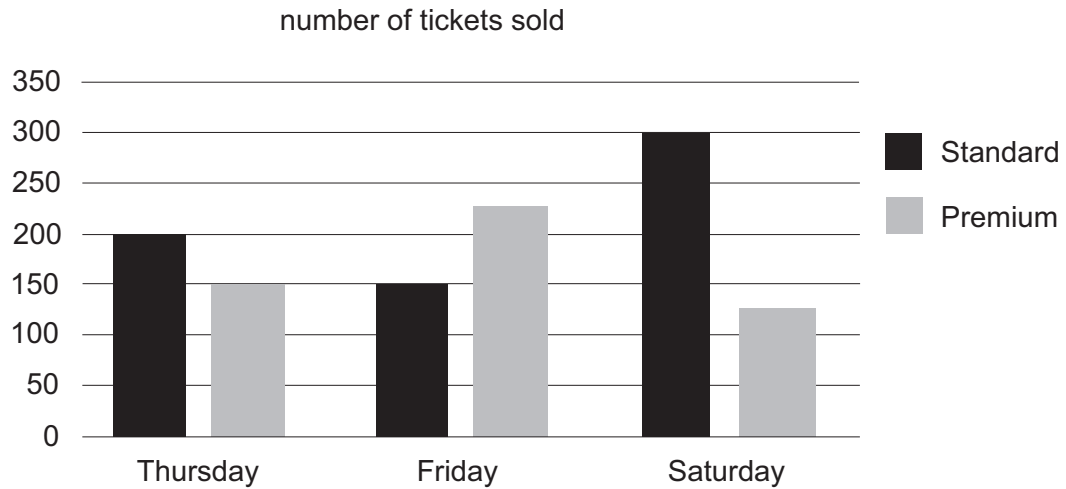

Premium tickets are more expensive than Standard tickets.

Which one of the following statements is correct?

- A The highest total sales income was for Thursday.
 - B The highest total sales income was for Friday.
 - C The highest total sales income could have been for Thursday or Friday.
 - D The highest total sales income could have been for Thursday or Saturday.
 - E The highest total sales income could have been for Friday or Saturday.
- 5 Three friends are training to run a marathon. Part of this training involves running steadily round a track in the local park. They are all at different stages in their training schedules so they run at different speeds. Alec completes each lap in 3 minutes, Barry takes 5 minutes and Colin takes 6 minutes.

They all leave the start line at the same time.

If they each maintain their running speed throughout the session, how many more laps will Alec have completed compared to Barry when the three of them next cross the start line together?

- A 2
- B 4
- C 5
- D 6
- E 10

- 6 The table below shows the amount of waste recycled each year, in thousands of tonnes, over a three-year period in 20 countries.

<i>country</i>	<i>recycling year 1</i>	<i>recycling year 2</i>	<i>recycling year 3</i>
Ambrosia	52	64	65
Buranda	60	72	80
Carbonda	20	27	40
Elbonia	32	34	40
Friponia	36	39	45
Grandia	20	35	60
Hoollasia	50	56	60
Ishlapia	33	41	44
Jackaran	36	44	48
Killumpa	40	55	70
Lateralialia	50	57	60
Moodle	80	98	90
Nalpha	32	44	48
Oritan	72	81	90
Phillim	66	69	70
Quaratus	80	90	100
Rutalia	75	76	90
Samalam	88	96	99
Tuddle	50	56	60
Ukliam	50	56	60

What is the biggest percentage increase in recycling in the table from year 1 to year 3?

- A 50%
- B 75%
- C 100%
- D 150%
- E 200%

7 Peter has drawn two diagrams showing information about the two cars owned by his parents:

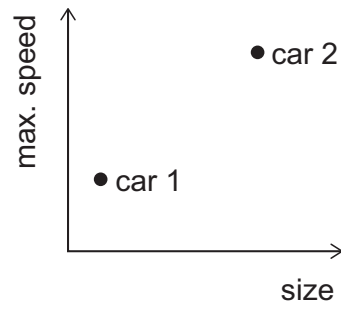
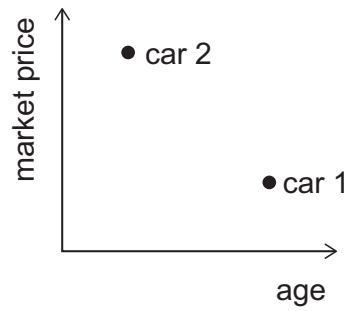

Which one of the following statements is **not** correct?

- A The more expensive car is newer.
- B The cheaper car is bigger.
- C The older car is slower.
- D The newer car is bigger.
- E The slower car is smaller.

8 A digital display consists of seven segments which light up in different combinations to produce digits. For example, to display the digit '1' the two right-hand segments light up as shown:



The display is used to show, in sequence, each of the digits 1 to 9.

What is the maximum and minimum number of times that any one segment lights up during this sequence?

	<i>maximum</i>	<i>minimum</i>
A	7	4
B	7	5
C	8	3
D	8	5
E	9	4

- 9 Sandi is planning a trip to the old city of Pordson. She wants to stay for four nights in order to visit all of the attractions, and one of the nights must be the Saturday so that she can attend a special music concert.

The table below shows the prices per night and details of the deals for the five main hotels in Pordson.

<i>Hotel</i>	<i>Mon</i>	<i>Tues</i>	<i>Weds</i>	<i>Thurs</i>	<i>Fri</i>	<i>Sat</i>	<i>Sun</i>		<i>Deal</i>
Grand	€60	€70	€70	€70	€50	€60	€60		3F2
Majestic	€40	€90	€70	€70	€40	€90	€40		SFSHP
Palace	€60	€90	€90	€70	€50	€90	€80		50%
Palms	€60	€80	€80	€50	€40	€60	€50		4FP3
Plaza	€70	€90	€90	€60	€50	€70	€50		CBK

Deals: 3F2 Stay 2 nights and get the 3rd night free
 SFSHP Stay Friday and get the Saturday night half price.
 50% 50% discount on all stays of 3 or more nights.
 4FP3 Stay 4 nights and get the cheapest night free.
 CBK €50 discount on stays of 3 or more nights.

What is the minimum that Sandi will need to spend on a hotel bill for her stay in Pordson?

- A €110
- B €120
- C €140
- D €145
- E €160

- 10 In March, 20 people voted for the position of chair of a committee. There were three potential candidates: Andrew, James and Roger.

In April, 11 of these people changed their votes, as follows:

- 3 people changed their vote from Andrew to James
- 2 people changed their vote from James to Roger
- 5 people changed their vote from Andrew to Roger
- 1 person changed their vote from Roger to James

Which one of these bar charts could **not** show the number of votes for the three candidates in March and April?

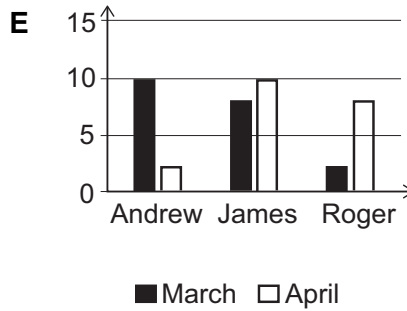
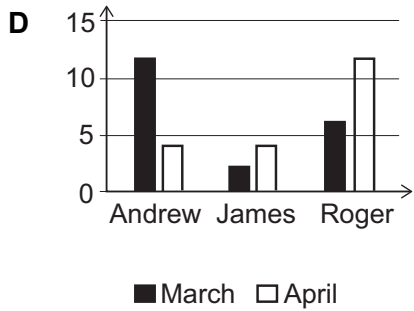
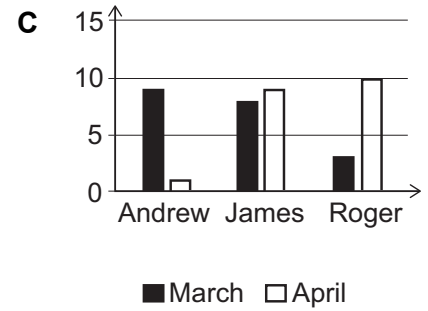
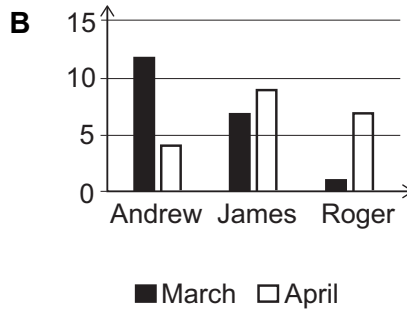
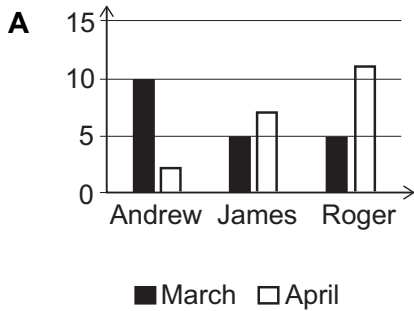

- 11 Alex and Sue are playing a game with a set of nine cards, numbered from 1 to 9. A 3×3 grid of cards is dealt onto the table. The cards for the next round have just been dealt and are as shown below.

5	1	8
3	6	2
9	7	4

The first player chooses two cards and scores the difference between the two numbers. The second player then chooses two cards from the seven that are left and scores the average of the two numbers. The highest score wins the round. Both players must choose cards that are either horizontally or vertically next to each other in the grid.

For this round of the game Alex has to decide whether to play first or second. She wants to make sure that she wins the round. If she has more than one possible winning move then she wants to achieve the highest score possible.

What should Alex choose to do?

- A play first and choose the 1 and 8
- B play first and choose the 3 and 9
- C play first and choose the 6 and 7
- D play first and choose the 7 and 9
- E play second

- 12 The single ferry to Pepper Island starts each day from mainland Seatown and crosses to the island port of Kaysville. It runs back and forth from 9:30 am to 4:10 pm on Saturdays, Sundays and Bank Holidays, and from 10:30 am to 2:20 pm from Monday to Friday.

MAY						
M	T	W	T	F	S	S
1	2	3	4	5	6	7
8	9	10	11	12	13	14
15	16	17	18	19	20	21
22	23	24	25	26	27	28
29	30	31				

highlighted days = Bank Holidays

Each crossing takes 50 minutes. Between crossings, there is a 10-minute stopover for cleaning and refuelling. This is extended to 20 minutes on Saturdays, Sundays and Bank Holidays to allow for the increased cleaning requirements.

What is the maximum number of crossings the ferry can make in May?

- A 140
- B 144
- C 154
- D 166
- E 186

- 13 Nathan is making a pair of trousers for his young son. The diagram shows the pattern for one piece. Four such pieces are needed.

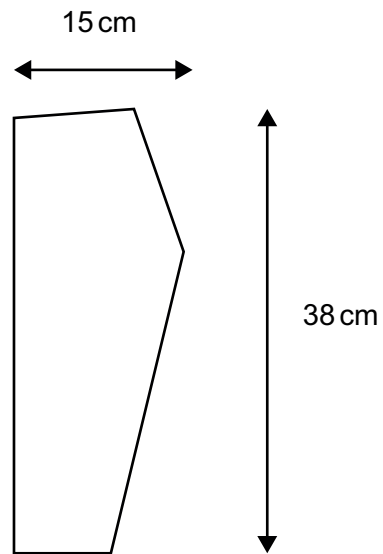

[diagram not to scale]

For simplicity he assumes that he will need a $15\text{ cm} \times 38\text{ cm}$ rectangle for each piece. The material comes in three widths with prices as shown:

<i>width</i>	<i>price / metre</i>
100 cm	£2.00
120 cm	£2.20
160 cm	£2.80

Material may be bought in lengths which are exact multiples of 10 cm.

What is the lowest price he can pay?

- A 42p
- B 56p
- C 60p
- D 66p
- E 80p

- 14 Arthur plans to modernise his bathroom. His design requires a 1600 mm × 700 mm bath. He wants side grips to help him get out of the bath, and because he doesn't want to choose the taps before ordering the bath he must have one which doesn't have pre-drilled tap holes.

A list from the bath catalogue is shown below:

<i>name</i>	<i>material</i>	<i>length</i>	<i>width</i>	<i>height</i>	<i>side-grips</i>	<i>pre-drilled tap holes</i>	<i>price (£)</i>
Balmoral	acrylic	1600	750	590	yes	no	159
Carola	acrylic	1600	700	610	yes	no	130
Dalton	steel	1600	700	580	no	no	112
Europa	steel	1600	700	590	yes	no	126
Gamma	steel	1600	700	580	yes	yes	135
Oporto	acrylic	1600	700	585	no	no	115
Polar	steel	1500	700	600	yes	no	120
Rocca	acrylic	1600	700	590	no	no	126
Sierra	steel	1600	700	580	yes	no	128
Victory	acrylic	1600	700	580	yes	no	149

How much will Arthur save by choosing the cheapest steel bath that fits his requirements rather than the cheapest acrylic bath that fits his requirements?

- A £2
- B £3
- C £4
- D £10
- E £18

- 15 The Head of Year 6 is planning an end-of-term treat for her students. The pie chart represents the numbers of votes cast by the children for each of the five possible outings.

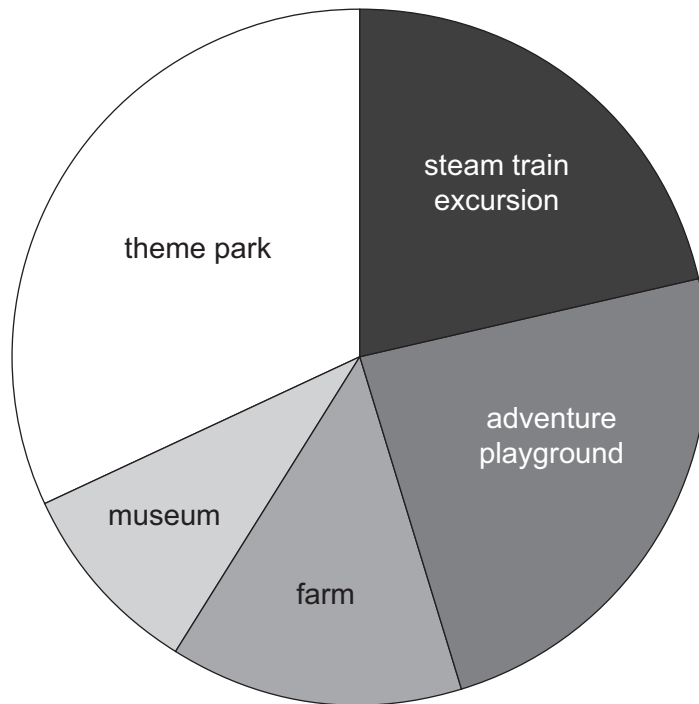

Which one of the following rows (**A–E**) could show the actual number of votes cast by the children for each of the options?

	<i>steam train excursion</i>	<i>adventure playground</i>	<i>farm</i>	<i>museum</i>	<i>theme park</i>	<i>total</i>
A	35	45	30	15	55	180
B	24	28	20	16	32	120
C	45	55	20	15	65	200
D	22	28	15	15	40	120
E	32	36	20	14	48	150

16 The drawing below shows an allotment shed.

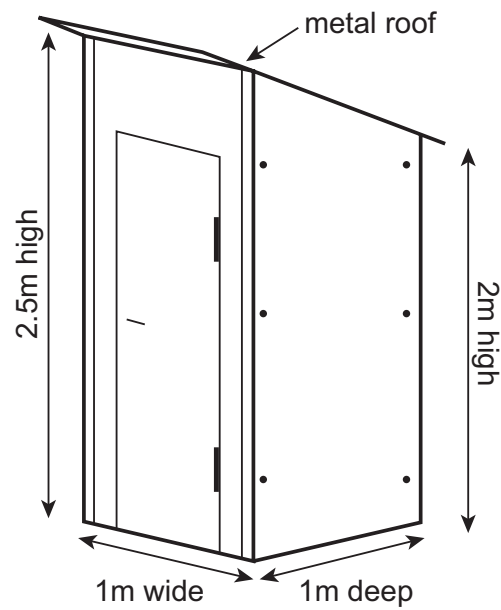

[diagram not to scale]

The four outside wood surfaces of the shed, including the door, need to be painted with three coats of paint. It takes 4 minutes to paint 1 square metre.

I have two identical sheds to paint and will take just one 20-minute tea break.

How long will it take to paint the two sheds?

- A 36 minutes
- B 1 hour and 48 minutes
- C 2 hours and 8 minutes
- D 3 hours and 36 minutes
- E 3 hours and 56 minutes

- 17 A school party consisting of 4 teachers and 20 students is visiting the theatre. Of the students, 8 are aged 15 years and 12 are aged 16 years. The following table shows the entry prices to the theatre.

<i>category</i>	<i>price</i>
Adult (16 years and over)	\$30
Child (5–15 years)	\$20
Under 5 years	free
Family ticket (2 adults and up to 2 children under 16 years)	\$90
Group ticket (8 people including at least 2 children under 16 years)	\$175
Supergroup ticket (any 8 people)	\$200

What is the least amount that the school party must pay for entry to the theatre?

- A \$525
- B \$530
- C \$545
- D \$550
- E \$560

18 Consider the following net, which forms a hexagonal prism:

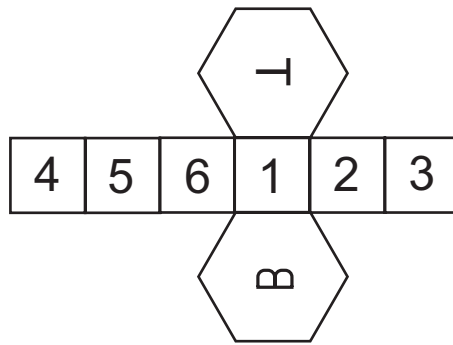

Which one of the following nets will form an identical prism?

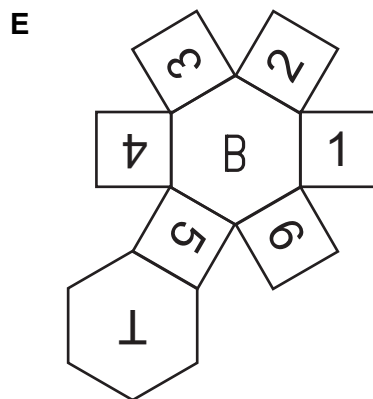
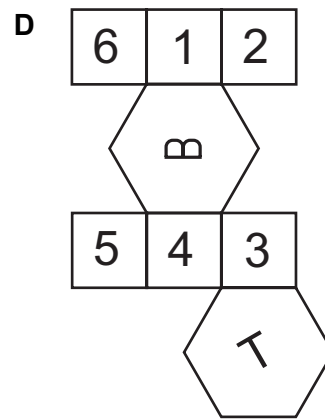
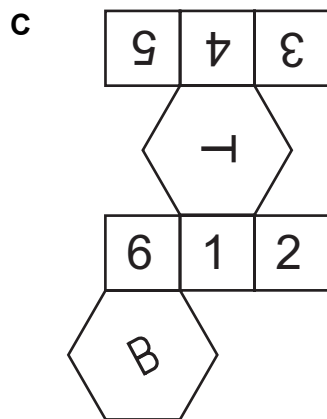
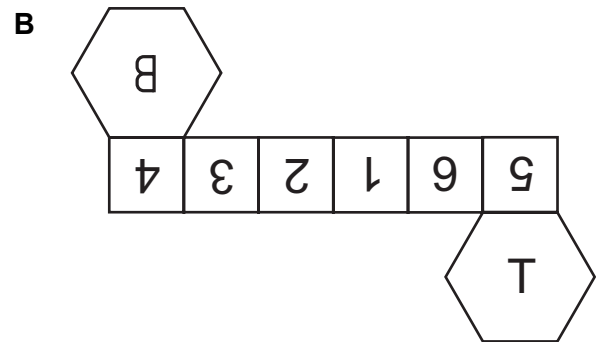
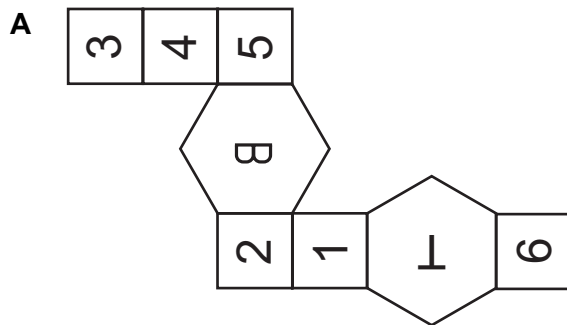

- 19** Sourdough, an ingredient of many bread products, is a fermented mixture of flour and water. At 8:00 am on Monday morning, I start with a mixture of 50 g flour and 50 g water. Each morning at 8:00 am I double the weight of the sourdough by adding equal weights of flour and water. I know that 1 g of the water content evaporates every hour.

The bread recipe that I would like to use requires 500 g of sourdough. I also want at least 50 g of sourdough left over so that I can continue growing it for next week's bread.

On which day am I going to have the necessary amount of sourdough?

- A** Tuesday
- B** Wednesday
- C** Thursday
- D** Friday
- E** Saturday

- 20** A 250 g bag of mixed nuts lists the contents on the packet as follows:

<i>nut</i>	<i>content</i>
almonds	20-30%
brazil nuts	10-20%
hazelnuts	5-15%
peanuts	30-40%
pecans	10-20%

As they are my favourite, I eat all the almonds in the packet and then re-weigh it. I find that the almond content was the minimum it could have been whilst being consistent with the labelling.

What is the largest possible peanut content of the nuts remaining in the bag after I have eaten the almonds?

- A** 40%
- B** 48%
- C** 50%
- D** 57%
- E** 60%

PART B Advanced Mathematics

- 21 The equation gives y in terms of x :

$$y = 3\left(\sqrt{\left(\frac{x+1}{2}\right)}\right) - 1$$

Which one of the following is a rearrangement for x in terms of y ?

- A $x = 2\left(\frac{y+1}{3}\right) - 1$
- B $x = 2\left(\frac{y+1}{3}\right) + 1$
- C $x = 2\left(\frac{y+1}{3}\right)^2 - 1$
- D $x = 2\left(\frac{y+1}{3}\right)^2 + 1$
- E $x = 3\left(\frac{y+1}{2}\right)^2 - 1$
- F $x = 3\left(\frac{y+1}{2}\right)^2 + 1$
- G $x = \left(\frac{2(y+1)}{3}\right)^2 - 1$

- 22 Two shops, X and Y, are having a sale.

Shop X reduces its prices by 10%.

Shop Y reduces its prices by $\frac{1}{4}$

Both shops have an identical shirt in the sale for £28.80

What was the difference between the original prices of this shirt in shops X and Y?

- A £4.00
- B £4.32
- C £5.00
- D £5.62
- E £6.40
- F £6.72

23 Find the complete set of values of x for which

$$1 + \frac{x^2 + 9x + 9}{x} > 0$$

- A $x < -1$ or $x > 0$
- B $-1 < x < 0$
- C $x < -9$ or $x > -1$
- D $-9 < x < -1$
- E $x < -9$ or $-1 < x < 0$
- F $-9 < x < -1$ or $x > 0$

24 The equation of a curve C is given by

$$y = \frac{x^2 - 2}{\sqrt{x}}$$

Find the gradient of C at the point $(2, \sqrt{2})$.

- A $\sqrt{2}$
- B $\frac{5}{4}\sqrt{2}$
- C $\frac{7}{4}\sqrt{2}$
- D $\frac{7}{2}\sqrt{2}$
- E $4\sqrt{2}$
- F $\frac{9}{2}\sqrt{2}$
- G $8\sqrt{2}$

25 The coefficient of x^3 in the expansion of $(2\sqrt{p} + 3x)^5$ is 8640.

What is the value of p ?

A 4

B 8

C 16

D 72

E 80

26 x satisfies the equation

$$\log_3(k + \log_5 x) = 1$$

Which one of the following is an expression for x in terms of k ?

A $x = 3^{5-k}$

B $x = 3^{5+k}$

C $x = 5^{3-k}$

D $x = 5^{3+k}$

E $x = 3^5 - k$

F $x = 3^5 + k$

G $x = 5^3 - k$

H $x = 5^3 + k$

27 A test consists of 20 questions.

10 of the questions each score 1 for a correct answer and 0 otherwise.

The other 10 questions each score 2 for a correct answer and 0 otherwise.

Jenna's mean score per question is 1.15

For Jenna's answers, the modal number of marks per question is 1.

For how many questions did Jenna score 0?

A 3

B 4

C 5

D 6

E 7

28 Find the complete set of possible values of the real constant k for which the equation

$$(x - 2)^3 - 12(x - 2) + k^2 = 0$$

has exactly one real root.

A $k < -4$ or $k > 4$

B $-4 < k < 4$

C $k < 0$ or $k > 4$

D $0 < k < 4$

E $k < -16$ or $k > 16$

F $-16 < k < 16$

G $-6 < k < 6$

H $k < -6$ or $k > 6$

29 The ratio of the number of boys to the number of girls in a class is 1 : 3

The number of boys in the class is n .

Two students are chosen at random from the class.

The probability that both the students are boys is p .

Which one of the following is a correct expression for n , the number of boys in the class?

A $n = \frac{3p-1}{9p-1}$

B $n = \frac{3p+1}{9p-1}$

C $n = \frac{1}{1-9p}$

D $n = \frac{1}{9p-1}$

E $n = \frac{4p-1}{16p-1}$

F $n = \frac{4p+1}{16p-1}$

G $n = \frac{1}{1-16p}$

H $n = \frac{1}{16p-1}$

30 R is the sum to infinity of the geometric progression: $1, \sqrt{0.3}, 0.3, 0.3\sqrt{0.3}, \dots$

S is the sum to infinity of the geometric progression: $1, -\sqrt{0.3}, 0.3, -0.3\sqrt{0.3}, \dots$

What is the value of $R - S$?

A $-\frac{20}{7}$

B $-\frac{2\sqrt{30}}{7}$

C $-\frac{2\sqrt{3}}{7}$

D $\frac{2\sqrt{3}}{7}$

E $\frac{2\sqrt{30}}{7}$

F $\frac{20}{7}$

31 P is the area of the region bounded by the curve $y = 5x - x^2$ and the x -axis.

Q is the area of the region between the curve $y = 5x - x^2$ and the line $y = 2x$

What is the ratio $Q : P$?

A 27 : 125

B 54 : 125

C 81 : 125

D 27 : 250

E 81 : 250

32 The cubic equation

$$f(x) = p^{\frac{2}{3}}x^3 + px^2 + p^{\frac{1}{3}}x + 3$$

where p is a positive constant, has exactly one point where $f'(x) = 0$

What is the value of p ?

A 0

B $\frac{1}{4}$

C $\frac{3}{4}$

D 1

E 3

F 6

33 Find the sum of the real roots of the equation

$$49^x - 7^{x+1} + 12 = 0$$

A 1

B 7

C $\log_{10} 12$

D $\log_{10} \left(\frac{12}{49} \right)$

E $\frac{\log_{10} 12}{\log_{10} 7}$

F $\frac{1}{\log_{10} 7}$

34 Consider the following three statements:

1 $x^2 - 3x + 2 = 0$ **if** $x = 1$

2 $x^2 - 3x + 2 = 0$ **only if** $x = 1$

3 $x^2 - 3x + 2 = 0$ **if and only if** $x = 1$

Which of the statements is/are true?

A none of them

B 1 only

C 2 only

D 3 only

E 1 and 2 only

F 1 and 3 only

G 2 and 3 only

H 1, 2 and 3

35 There are only red balls and green balls in a bag.

When I pick a ball from the bag, the probability of picking a red ball is p and the probability of picking a green ball is q , where $q \geq p$.

I pick a ball from the bag and record its colour. I then replace the ball in the bag.

I repeat this procedure once.

Given that

$$P(\text{the balls are of the same colour}) - P(\text{the balls are of different colours}) = \frac{1}{4}$$

find the value of

$$\frac{q}{p} - \frac{p}{q}$$

A 0

B $\frac{3}{2}$

C $\frac{5}{6}$

D $\frac{8}{3}$

E $\frac{247}{48}$

36 The expression $(ax + b)(cx + d)$ is expanded, where a, b, c and d are real numbers.

Consider the following three conditions:

condition 1 $b = -d$

condition 2 $ad = -bc$

condition 3 $a = c = 1$ and $b = -d$

Which of these conditions is/are **sufficient** for the expansion of $(ax + b)(cx + d)$ to equal $px^2 + q$, for all x , where p and q are real numbers?

	condition 1	condition 2	condition 3
A	not sufficient	not sufficient	not sufficient
B	not sufficient	not sufficient	sufficient
C	not sufficient	sufficient	not sufficient
D	not sufficient	sufficient	sufficient
E	sufficient	not sufficient	not sufficient
F	sufficient	not sufficient	sufficient
G	sufficient	sufficient	not sufficient
H	sufficient	sufficient	sufficient

END OF TEST

Economics Admissions Assessment – Section 1 2019

D563/11

Candidate number

K

Centre number

Date of birth (DD MM YYYY)

First name(s)

Surname / Family name

Fill in the appropriate circle for your chosen answer e.g.

A B C D E
○ ● ○ ○ ○

Use a soft pencil. If you make a mistake, erase thoroughly and try again.

* 4 8 3 8 5 2 3 5 9 4 *

Part A: Problem Solving

- | | | | |
|----|-----------|----|-----------|
| 1 | A B C D E | 11 | A B C D E |
| | ○ ○ ○ ○ ○ | | ○ ○ ○ ○ ○ |
| 2 | A B C D E | 12 | A B C D E |
| | ○ ○ ○ ○ ○ | | ○ ○ ○ ○ ○ |
| 3 | A B C D E | 13 | A B C D E |
| | ○ ○ ○ ○ ○ | | ○ ○ ○ ○ ○ |
| 4 | A B C D E | 14 | A B C D E |
| | ○ ○ ○ ○ ○ | | ○ ○ ○ ○ ○ |
| 5 | A B C D E | 15 | A B C D E |
| | ○ ○ ○ ○ ○ | | ○ ○ ○ ○ ○ |
| 6 | A B C D E | 16 | A B C D E |
| | ○ ○ ○ ○ ○ | | ○ ○ ○ ○ ○ |
| 7 | A B C D E | 17 | A B C D E |
| | ○ ○ ○ ○ ○ | | ○ ○ ○ ○ ○ |
| 8 | A B C D E | 18 | A B C D E |
| | ○ ○ ○ ○ ○ | | ○ ○ ○ ○ ○ |
| 9 | A B C D E | 19 | A B C D E |
| | ○ ○ ○ ○ ○ | | ○ ○ ○ ○ ○ |
| 10 | A B C D E | 20 | A B C D E |
| | ○ ○ ○ ○ ○ | | ○ ○ ○ ○ ○ |

Part B: Advanced Mathematics

- | | | | |
|----|-----------------|----|-----------------|
| 21 | A B C D E F G | 29 | A B C D E F G H |
| | ○ ○ ○ ○ ○ ○ ○ | | ○ ○ ○ ○ ○ ○ ○ ○ |
| 22 | A B C D E F | 30 | A B C D E F |
| | ○ ○ ○ ○ ○ ○ | | ○ ○ ○ ○ ○ ○ |
| 23 | A B C D E F | 31 | A B C D E |
| | ○ ○ ○ ○ ○ ○ | | ○ ○ ○ ○ ○ |
| 24 | A B C D E F G | 32 | A B C D E F |
| | ○ ○ ○ ○ ○ ○ ○ | | ○ ○ ○ ○ ○ ○ |
| 25 | A B C D E | 33 | A B C D E F |
| | ○ ○ ○ ○ ○ | | ○ ○ ○ ○ ○ ○ |
| 26 | A B C D E F G H | 34 | A B C D E F G H |
| | ○ ○ ○ ○ ○ ○ ○ ○ | | ○ ○ ○ ○ ○ ○ ○ ○ |
| 27 | A B C D E | 35 | A B C D E |
| | ○ ○ ○ ○ ○ | | ○ ○ ○ ○ ○ |
| 28 | A B C D E F G H | 36 | A B C D E F G H |
| | ○ ○ ○ ○ ○ ○ ○ ○ | | ○ ○ ○ ○ ○ ○ ○ ○ |



K

ECAA S1 2019 Answer Key

Question	Key
1	C
2	D
3	C
4	E
5	B
6	E
7	B
8	C
9	C
10	C
11	E
12	B
13	B
14	C
15	E
16	E
17	A
18	C
19	D
20	C
21	C
22	E
23	F
24	C
25	B
26	C
27	B
28	A
29	E
30	E
31	A
32	E
33	E
34	B
35	D
36	D

**ECONOMICS
ADMISSIONS ASSESSMENT****D563/12****Wednesday 30 October 2019****40 minutes****SECTION 2**

Candidate number	K							Centre number						
------------------	---	--	--	--	--	--	--	---------------	--	--	--	--	--	--

Date of birth														
	d	d		m	m		y	y	y	y				

First name (s)	
----------------	--

Surname / Family name	
-----------------------	--

INSTRUCTIONS TO CANDIDATES

Please read these instructions carefully, but do not open the question paper until you are told that you may do so. This paper is Section 2 of 2.

This question paper requires you to read a single passage and complete a related task.

You should write your answer in the space provided in this question paper. Please complete this section in **black pen**.

You can use the blank inside front and back covers for rough working or notes, but no extra paper is allowed. Only answers in the space indicated in the paper will be marked.

Dictionaries and calculators are NOT permitted.

Please wait to be told you may begin before turning this page.

This question paper consists of 10 printed pages and 2 blank pages.



This page is intentionally left blank for your rough working or notes.

Read the article 'Global imbalances, a pre-crisis scourge, are back' taken from *The Economist* (October 26th 2016). Based on this text, complete the task below.

TASK

- **Set out two ways in which global imbalances can cause problems for the development of the world economy.**
- **Suggest possible reasons why an individual country might experience persistent current account surpluses or deficits.**

Your answer will be assessed taking into account your ability to construct a reasoned, insightful and logically consistent argument with clarity and precision.

Global imbalances, a pre-crisis scourge, are back

Brad Setser, an economist at the Council on Foreign Relations, is the author of a new discussion paper looking at the 'return of the East Asian savings glut'. A summary of his paper begins in arresting fashion:

The combined savings of China, Japan, Korea, Taiwan, and the two city-states of Hong Kong and Singapore is about 40 percent of their collective GDP, a thirty-five-year high.

Prior to the global financial crisis of 2007–08, many economists fretted about the problem of global imbalances. Measurement error aside, global trade balances, surpluses in some countries offset deficits in others. Yet the magnitudes of those surpluses and deficits can be small or large. In the early 1990s, surpluses and deficits were each around 0.5% of global GDP. They expanded rapidly therefore, to about 2% of global GDP on the eve of the crisis. After shrinking dramatically during the crisis and global recession, imbalances have begun to rebound and are now back to about 1.5% of GDP.

Why do such imbalances matter? They can create problems in a few ways. Large surpluses can be a side effect of very high savings rates, for example. The large imbalances of the 2000s seemed to reflect unnaturally high savings, which contributed to a 'global savings glut' that depressed interest rates and encouraged reckless borrowing. Large imbalances can be unhealthy for countries on both sides of the zero; the deficit countries consuming more than they produce risk accumulating unmanageably high debts, while surplus countries can suffer from economic distortions associated with policies (like currency intervention and other means of suppressing consumption) that boost net exports. These sorts of problems still apply in some circumstances.

Yet another worry has grown more salient in the post-crisis period: the demand drain imposed on the global economy by surplus countries. A rising surplus in one country implies a rising deficit in another. That deficit represents a demand drain; spending that might otherwise have taken place within the economy flowing abroad into another economy. That drain is not a terribly big deal when the deficit economy can easily use monetary or fiscal policy to step on the accelerator and boost domestic spending: from the government, for instance, or through increased domestic investment. When interest rates are near zero and political constraints prevent governments from using active fiscal policy, the demand drain is dangerous: it generally results in weaker demand, and slower growth.

Imbalances today look slightly different than they did a decade ago. Then, America accounted for nearly all of the global deficit, while China and oil-exporting economies were responsible for most of the surplus. Oil balances are less important now, since America produces much more oil domestically than it used to, and since global oil prices have fallen. Instead, the surplus countries are high-savings goods exporters in Europe and East Asia. The big deficit economies, somewhat strikingly, are now

America, Australia, Britain and Canada. These economies are all of a type: English-speaking, of course. Rich. But they are also highly financialised economies which specialise in the export of high-value services (and safe assets, in the form of both government securities and land). The split is a weird one which deserves more investigation.

The tricky matter is to work out what will happen next to global imbalances. Mr Setser notes that East Asian surpluses are rising partly because rates of domestic saving are high, but also because investment rates in countries like China and Korea have been falling – and there is good reason to think that China’s extraordinarily high rate of domestic investment will need to fall much more in the near future. Meanwhile, Japan continues to run a rather large budget deficit; were it not for that, its current-account surplus would likely be larger. And in Europe, recovery has been built atop large and growing current-account surpluses. Depending on how Brexit unfolds, Britain, which had been a rather generous contributor to global demand thanks to its whopping current-account deficit, might find itself pushed rather roughly by financial reality toward a more balanced current account – as the tumbling pound forces Britons to cut back on imports, for example.

All of which implies more pressure on the remaining sources of global demand. Rising imbalances do not necessarily mean another crisis is inevitable, lurking right around the corner. It does suggest a growing vulnerability across the global economy to any future shocks to demand, from a sharp China slowdown, for instance, or excessively rapid increases in American interest rates. The news, in other words, could be better.

Write your answer in the space below.

A series of horizontal dotted lines for writing an answer.

This page is intentionally left blank for your rough working or notes.

K