

NATURAL SCIENCES  
ADMISSIONS ASSESSMENT

D568/11

Wednesday 31 October 2018

80 minutes

## SECTION 1

## INSTRUCTIONS TO CANDIDATES

Please read these instructions carefully, but do not open this question paper until you are told that you may do so. This paper is Section 1 of 2.

A separate answer sheet is provided for this paper. Please check you have one. You also require a soft pencil and an eraser.

Please complete the answer sheet with your candidate number, centre number, date of birth, and name.

At the end of 80 minutes, your supervisor will collect this question paper and answer sheet before giving out Section 2.

This paper contains **five** parts: **A, B, C, D,** and **E**.

All candidates should complete **Part A** Mathematics.

All candidates should then complete **two** further parts chosen from:

<b>Part B</b>	Physics
<b>Part C</b>	Chemistry
<b>Part D</b>	Biology
<b>Part E</b>	Advanced Mathematics and Advanced Physics

Each part has 18 multiple-choice questions. There are no penalties for incorrect responses, only marks for correct answers, so you should attempt all of the questions in your **three** parts. Each question is worth one mark.

For each question, choose the **one** option you consider correct and record your choice on the separate answer sheet. If you make a mistake, erase thoroughly and try again.

You **must** complete the answer sheet within the time limit.

You can use the question paper for rough working, but **no extra paper** is allowed. Only your responses on the answer sheet will be marked.

Dictionaries and calculators may NOT be used.

**Please wait to be told you may begin before turning this page.**

This question paper consists of 74 printed pages and 6 blank pages.

PV2



**BLANK PAGE**

**Paper content**

PART A Mathematics .....	5
PART B Physics .....	21
PART C Chemistry .....	37
PART D Biology .....	49
PART E Advanced Mathematics and Advanced Physics.....	67

**BLANK PAGE**

**PART A Mathematics**

- 1 A group of drivers, consisting of 200 women and 300 men, was asked if they passed their driving test at the first attempt.

Altogether 167 of the group said they passed at the first attempt.

Of the women, 143 said they did not pass at the first attempt.

How many of the men said they passed at the first attempt?

- A 10
- B 24
- C 33
- D 57
- E 110
- F 133
- G 157

- 2 A cuboid has sides of length  $x$ ,  $\sqrt{2}x$  and  $2x$ , measured in cm.

The volume, in  $\text{cm}^3$ , of the cuboid is numerically equal to twice the total surface area, in  $\text{cm}^2$ , of the cuboid.

What is the value of  $x$ ?

- A 10
- B  $6 + 2\sqrt{2}$
- C 5
- D  $3 + \sqrt{2}$
- E  $\frac{5}{2}$
- F  $\frac{3}{2} + \frac{1}{2}\sqrt{2}$

- 3 The line joining the points with coordinates  $(p, p - 1)$  and  $(1 - p, 2p)$  is parallel to the line with equation  $2x + 3y + 1 = 0$

What is the value of  $p$ ?

- A  $-1$
- B  $-\frac{1}{7}$
- C  $\frac{1}{9}$
- D  $\frac{1}{8}$
- E  $1$
- F  $\frac{5}{4}$
- G  $2$
- H  $5$

- 4 A rectangle  $PQRS$  is drawn inside a circle, with its vertices on the circumference of the circle.

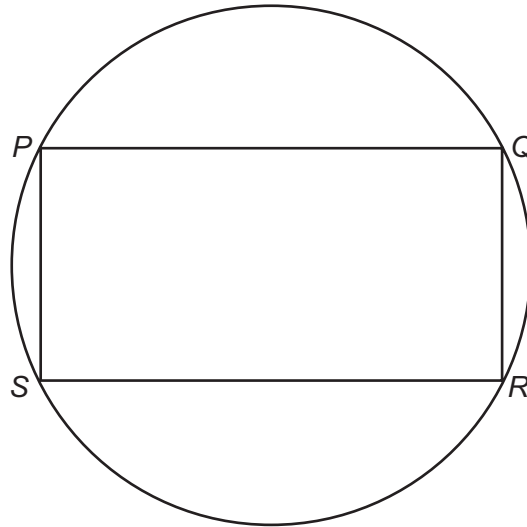

[diagram not to scale]

The ratio of the length of  $PQ$  to the length of  $QR$  is  $2 : 1$

The area of the rectangle  $PQRS$  is  $96 \text{ cm}^2$ .

What is the radius, in cm, of the circle?

- A  $\sqrt{6}$
- B 3
- C  $3\sqrt{2}$
- D  $2\sqrt{15}$
- E  $4\sqrt{6}$
- F 12
- G  $12\sqrt{2}$
- H  $8\sqrt{15}$



- 5 The expected number of bottles of water sold in a day at a sports ground is directly proportional to the square of the average outside temperature, in degrees Celsius, for that day.

On a day when the average outside temperature is  $16^{\circ}\text{C}$ , 64 bottles of water, the expected number, are sold.

On a warmer day, when the average outside temperature is  $T^{\circ}\text{C}$ , 256 bottles of water are sold, which is 31 bottles more than the expected number for that day.

What is the value of  $T$ ?

- A 7.5
- B  $\sqrt{450}$
- C 30
- D 32
- E  $\sqrt{1148}$
- F 56.25

6

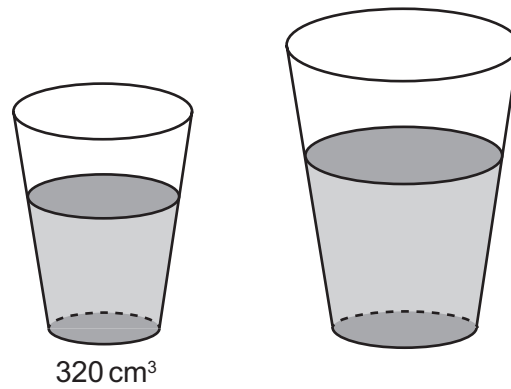

[diagram not to scale]

At a cinema, drinks are sold in regular and large sizes.

The cups for these are mathematically similar.

The ratio of the heights of the cups and the ratio of the depths of the drinks are both 4 : 5

The volume of drink in a regular size cup is 320 cm<sup>3</sup>.

What is the volume, in cm<sup>3</sup>, of drink in a large size cup?

- A 384
- B 400
- C 500
- D 576
- E 625
- F 640

7 The mean of  $n$  numbers is  $p$

The mean of two of these numbers is  $q$

The mean of the remaining numbers is 10

Which of the following is a correct expression for  $n$  in terms of  $p$  and  $q$ ?

**A**  $\frac{2(q-10)}{(p-10)}$

**B**  $\frac{2(q-10)}{(10-p)}$

**C**  $\frac{2(q-10)}{(p+10)}$

**D**  $\frac{2(10-q)}{(p+10)}$

**E**  $\frac{2(10+q)}{(p-10)}$

**F**  $\frac{2(10+q)}{(10-p)}$

8 The straight lines

$$5x + 2y = 20$$

$$y = 3x - 23$$

$$x = 0$$

enclose a region with area  $K$  square units.

What is the value of  $K$ ?

**A** 39

**B** 78

**C** 99

**D** 129

**E** 198

**F** 258

9 A scale model of a cylindrical pillar is to be made.

The full-sized pillar has a volume of  $12\pi\text{m}^3$ .

The model will use a length scale of 1 : 40

The model is to be a solid cylinder made of a plastic which has a density of  $\frac{4}{3}\text{g cm}^{-3}$ .

What is the mass of the model in grams?

A  $\frac{9}{640}\pi$

B  $\frac{1}{40}\pi$

C  $40\pi$

D  $\frac{1125}{8}\pi$

E  $250\pi$

F  $10\,000\pi$

G  $225\,000\pi$

H  $400\,000\pi$

10

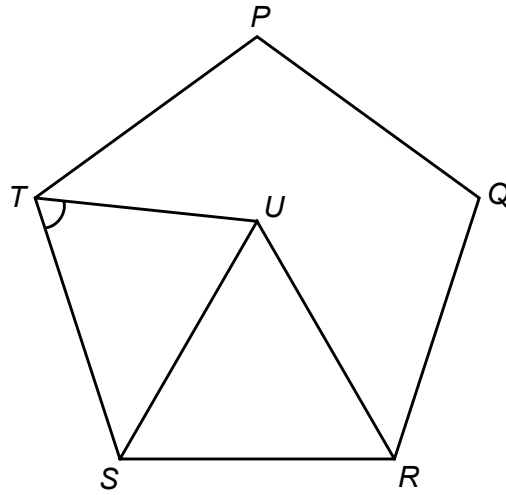

[diagram not to scale]

$PQRST$  is a regular pentagon.

$RSU$  is an equilateral triangle.

What is the size of angle  $STU$ ?

- A  $48^\circ$
- B  $54^\circ$
- C  $60^\circ$
- D  $66^\circ$
- E  $84^\circ$

11 The original price of an item is  $p$

The price is **increased by** 125%

The increased price is then **decreased by** 40% to  $q$

The relationship between  $p$  and  $q$  can be expressed as  $mp = q$

What is the value of  $m$ ?

A  $\frac{7}{20}$

B  $\frac{17}{20}$

C  $\frac{27}{20}$

D  $\frac{33}{20}$

E  $\frac{37}{20}$

12 80% of a number is equal to two-thirds of a second number.

The whole number ratio of the first number to the second number in its lowest terms is  $x:y$

What is the value of  $x - y$ ?

A 7

B 2

C 1

D 0.2

E -0.2

F -1

G -2

H -7

13 Q is 5 km away from  $P$  on a bearing of  $065^\circ$

$R$  is 5 km away from  $Q$  on a bearing of  $155^\circ$

What is the bearing of  $P$  from  $R$ ?

A  $070^\circ$

B  $110^\circ$

C  $225^\circ$

D  $270^\circ$

E  $290^\circ$

F  $315^\circ$

G  $335^\circ$

14 With school lunch, students can select tomato sauce, or mayonnaise, or both, or neither.

$n$  students selected both.

$3n + 1$  students selected tomato sauce.

$3n - 1$  students selected **only** mayonnaise.

There were  $7n + 5$  students in the group.

The probability of a student, chosen at random, selecting **only** mayonnaise is  $\frac{1}{3}$

By finding  $n$ , what is the probability of a student, chosen at random, selecting **only** tomato sauce?

A  $\frac{3}{11}$

B  $\frac{7}{26}$

C  $\frac{13}{33}$

D  $\frac{3}{8}$

E  $\frac{7}{13}$

15

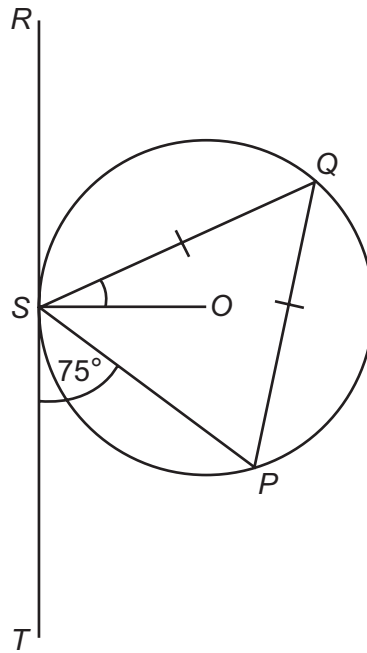

[diagram not to scale]

The line segment  $RT$  is a tangent at the point  $S$  to a circle with centre  $O$

$Q$  and  $P$  are points on the circumference of the circle such that  $QS = QP$

Angle  $PST = 75^\circ$

What is the size of angle  $QSO$ ?

- A  $15^\circ$
- B  $30^\circ$
- C  $37.5^\circ$
- D  $45^\circ$
- E  $52.5^\circ$
- F  $60^\circ$
- G  $67.5^\circ$
- H  $75^\circ$



16

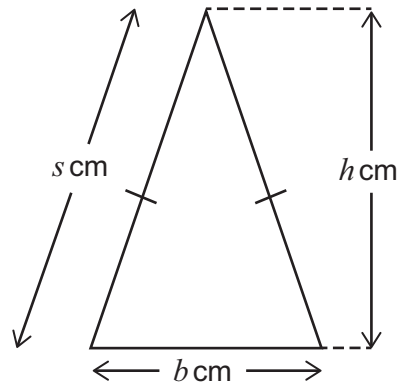

[diagram not to scale]

The vertical height  $h$  cm of an isosceles triangle is 3 cm longer than the base length of  $b$  cm.

The sloping side is of length  $s$  cm.

The area of the triangle is  $14 \text{ cm}^2$ .

There is one value of  $s$  which satisfies these conditions.

Within which range does this value of  $s$  lie?

- A  $5 < s < 6$
- B  $6 < s < 7$
- C  $7 < s < 8$
- D  $8 < s < 9$
- E  $9 < s < 10$
- F  $10 < s < 11$

- 17 The first five terms of a sequence in order are:

2    17    42    77    122

The  $n^{\text{th}}$  term of this sequence is  $pn^2 + q$  where  $p$  and  $q$  are integers.

What is the value of  $\frac{p-q}{p+q}$ ?

- A  $\frac{1}{4}$
- B  $\frac{1}{2}$
- C 1
- D  $\frac{23}{17}$
- E  $\frac{13}{7}$
- F 2
- G 4
- H 14

- 18 A bag contains 6 red and 6 green sweets. The sweets are identical apart from their colour.

A child takes a sweet at random from the bag.

If the sweet is red, the child stops taking sweets.

If the sweet is green, it is not replaced and the child takes another sweet.

This continues until a red sweet is taken at which point the child stops taking sweets.

What is the probability that the child takes **more** green sweets than red sweets?

A  $\frac{3}{22}$

B  $\frac{5}{22}$

C  $\frac{3}{11}$

D  $\frac{1}{2}$

E  $\frac{8}{11}$

F  $\frac{17}{22}$

**BLANK PAGE**

**PART B Physics**

- 19** An unstable nucleus X becomes a stable nucleus Y after a succession of decays, during which a total of 5 alpha particles and 2 beta ( $\beta^-$ ) particles are emitted.

How many fewer protons does nucleus Y contain than nucleus X?

- A** 6
- B** 8
- C** 10
- D** 12
- E** 14
- F** 16
- G** 18
- H** 20

- 20 The diagram shows three resistors  $R_1$ ,  $R_2$  and  $R_3$  connected in series with a battery of constant voltage. The resistance of each resistor and the corresponding current are also shown.

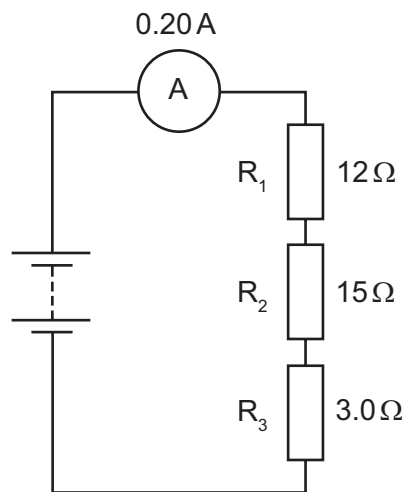

Resistor  $R_3$  is now removed and the circuit is reconnected.

What is the new current in the circuit?

- A 0.20 A
- B 0.22 A
- C 0.33 A
- D 0.40 A
- E 0.50 A
- F 2.0 A
- G 6.0 A

21 When travelling in a vacuum, visible light has a wavelength between 400 nm and 700 nm.

The speed of light in a vacuum is  $3.0 \times 10^8 \text{ ms}^{-1}$ .

What can be concluded about **ultraviolet** radiation from this information?

- A It has a **maximum** frequency of  $2.7 \times 10^{14} \text{ Hz}$
- B It has a **maximum** frequency of  $4.3 \times 10^{14} \text{ Hz}$
- C It has a **maximum** frequency of  $7.5 \times 10^{14} \text{ Hz}$
- D It has a **maximum** frequency of  $1.0 \times 10^{15} \text{ Hz}$
- E It has a **minimum** frequency of  $2.7 \times 10^{14} \text{ Hz}$
- F It has a **minimum** frequency of  $4.3 \times 10^{14} \text{ Hz}$
- G It has a **minimum** frequency of  $7.5 \times 10^{14} \text{ Hz}$
- H It has a **minimum** frequency of  $1.0 \times 10^{15} \text{ Hz}$



- 22 The graph is the speed–time graph for a bus travelling in a straight line between two stops.

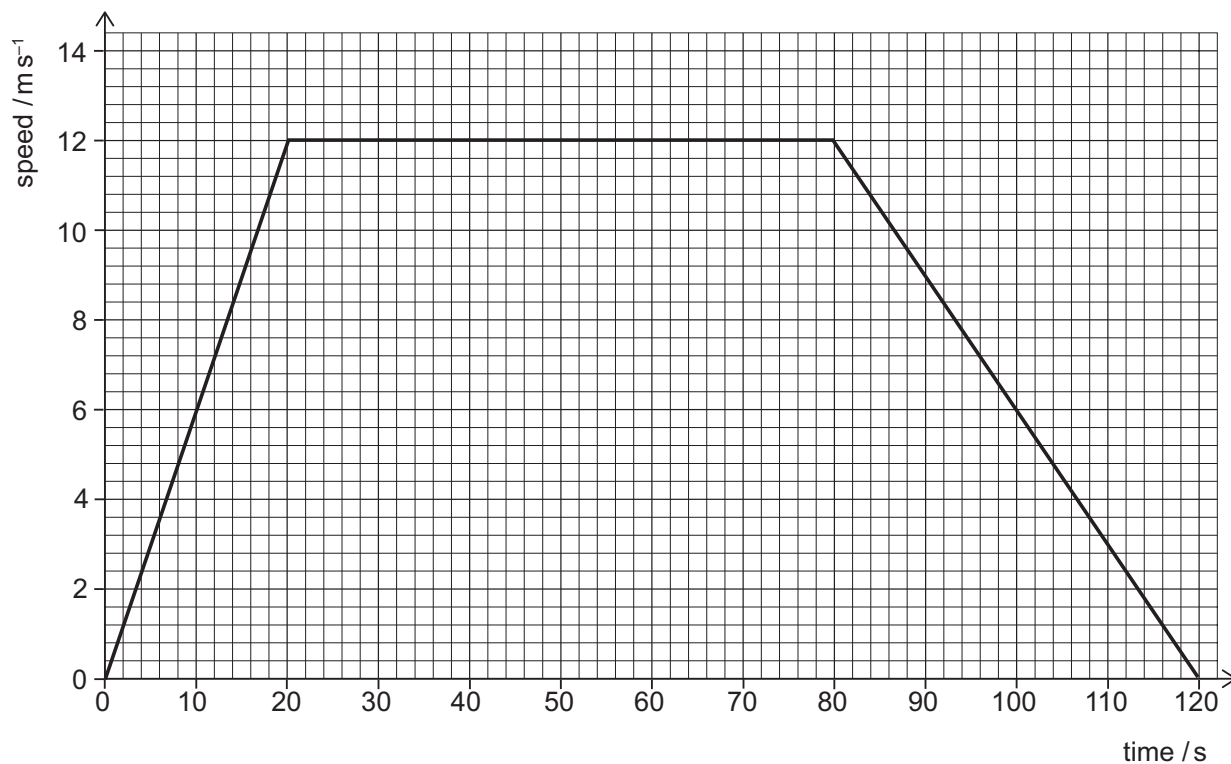

What is the average speed of the bus during this time?

- A  $3.0 \text{ m s}^{-1}$
- B  $4.5 \text{ m s}^{-1}$
- C  $6.0 \text{ m s}^{-1}$
- D  $8.0 \text{ m s}^{-1}$
- E  $9.0 \text{ m s}^{-1}$
- F  $11 \text{ m s}^{-1}$
- G  $12 \text{ m s}^{-1}$

- 23** A filament lamp working at its operating voltage converts electrical energy at a rate of 100 W.

The lamp has an efficiency of 5.0%.

How much energy is wasted by the lamp in 10 minutes?

- A** 50 J
- B** 950 J
- C** 1000 J
- D** 3000 J
- E** 57 000 J
- F** 60 000 J

- 24** A student is investigating heat flow along a solid uniform metal bar.

The bar has length  $l$ , cross-sectional area  $A$ , and has its ends maintained at temperatures  $T_1$  and  $T_2$  (where  $T_1 > T_2$ ).

Which relationship represents the rate of heat flow  $P$  along the bar?

(Assume that there is no heat transfer through the sides of the bar.)

- A**  $P \propto \frac{(T_1 - T_2)}{Al}$
- B**  $P \propto \frac{(T_1 + T_2)}{Al}$
- C**  $P \propto \frac{A(T_1 - T_2)}{l}$
- D**  $P \propto \frac{A(T_1 + T_2)}{l}$
- E**  $P \propto \frac{l}{A(T_1 - T_2)}$
- F**  $P \propto \frac{l}{A(T_1 + T_2)}$
- G**  $P \propto \frac{Al}{(T_1 - T_2)}$
- H**  $P \propto \frac{Al}{(T_1 + T_2)}$

- 25** The potential difference across the motor in an electric car is 400 V and the current in the motor is 1250 A.

The car accelerates along a horizontal road from rest for 4.0 s.

The efficiency of the overall system is 45%.

What is the kinetic energy of the car at the end of the 4.0 s?

(Ignore energy losses due to air resistance and due to friction between the tyres and the road.)

- A** 225 000 J
  - B** 500 000 J
  - C** 900 000 J
  - D** 1 250 000 J
  - E** 2 000 000 J
- 26** The momentum of a small object moving in a straight line is  $24 \text{ kg m s}^{-1}$  and its kinetic energy is 96 J.
- What is the mass of the object?
- A** 3.0 kg
  - B** 4.0 kg
  - C** 6.0 kg
  - D** 8.0 kg
  - E** 12 kg

- 27 A radioactive isotope decays in a single step to a stable isotope.

A radiation detector is placed very near to a sample of the radioactive isotope in a laboratory. The count rate on the detector changes as time elapses. The graph shows how the measured count rate changes with time.

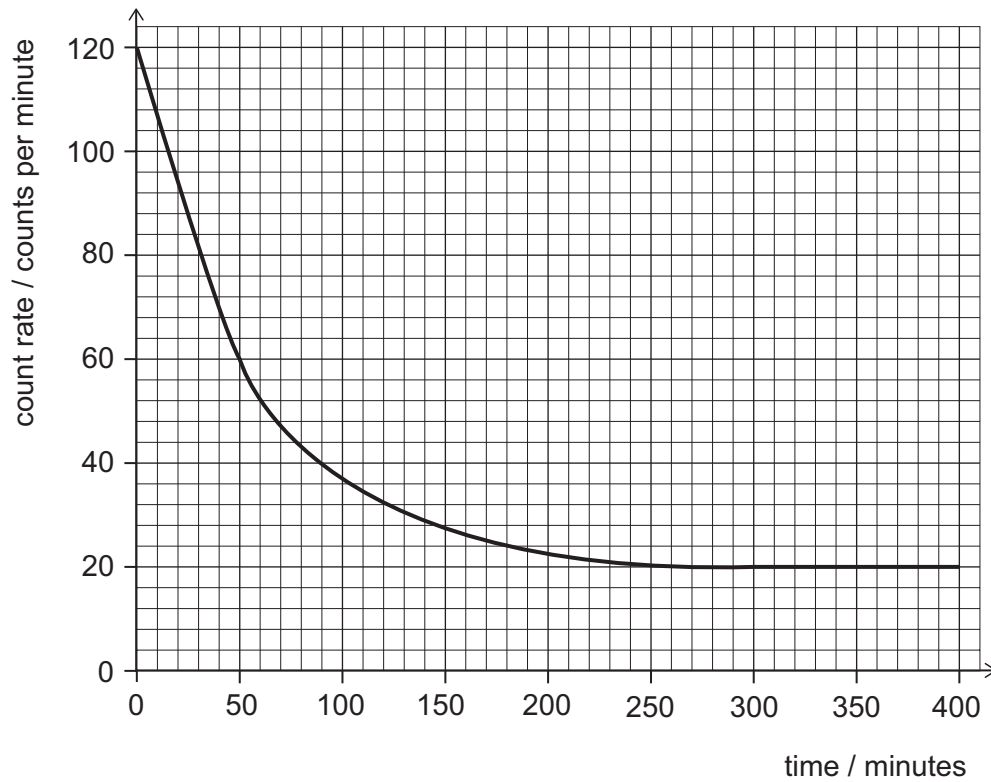

What is the background count rate and what is the half-life of the isotope?

	<i>background count rate</i> / counts per minute	<i>half-life of isotope</i> / minutes
<b>A</b>	20	40
<b>B</b>	20	50
<b>C</b>	20	60
<b>D</b>	20	65
<b>E</b>	120	40
<b>F</b>	120	50
<b>G</b>	120	60
<b>H</b>	120	65

- 28** A rock falling vertically experiences an air resistance force of 12 N at an instant when its acceleration is  $2.0 \text{ m s}^{-2}$  downwards.

What is the mass of the rock?

(gravitational field strength =  $10 \text{ N kg}^{-1}$ )

- A** 1.0 kg
  - B** 1.2 kg
  - C** 1.5 kg
  - D** 6.0 kg
  - E** 10 kg
  - F** 12 kg
  - G** 15 kg
  - H** 60 kg
- 29** A transverse wave with an amplitude of 4.0 cm and a frequency of 10 Hz travels along a rope at a speed of  $2.4 \text{ m s}^{-1}$ .

What is the total distance travelled by a particle in the rope in a time of 20 s?

- A** 2.4 m
- B** 4.8 m
- C** 8.0 m
- D** 16 m
- E** 32 m
- F** 48 m

- 30** A student places a measuring cylinder on a balance. She pours a volume  $V$  of water into the measuring cylinder, and finds that the mass of the measuring cylinder and water together is 290 g.

She then empties the measuring cylinder and dries it before putting it back on the balance.

She now pours the same volume  $V$  of olive oil into the measuring cylinder, and finds that the mass of the measuring cylinder and olive oil together is 270 g.

What is the mass of the measuring cylinder?

(densities: olive oil =  $0.90 \text{ g cm}^{-3}$ ; water =  $1.0 \text{ g cm}^{-3}$ )

- A** 18 g
- B** 20 g
- C** 90 g
- D** 180 g
- E** 200 g

- 31 A skydiver of weight 1000 N falls vertically.

The distance–time graph for the skydiver is shown below.

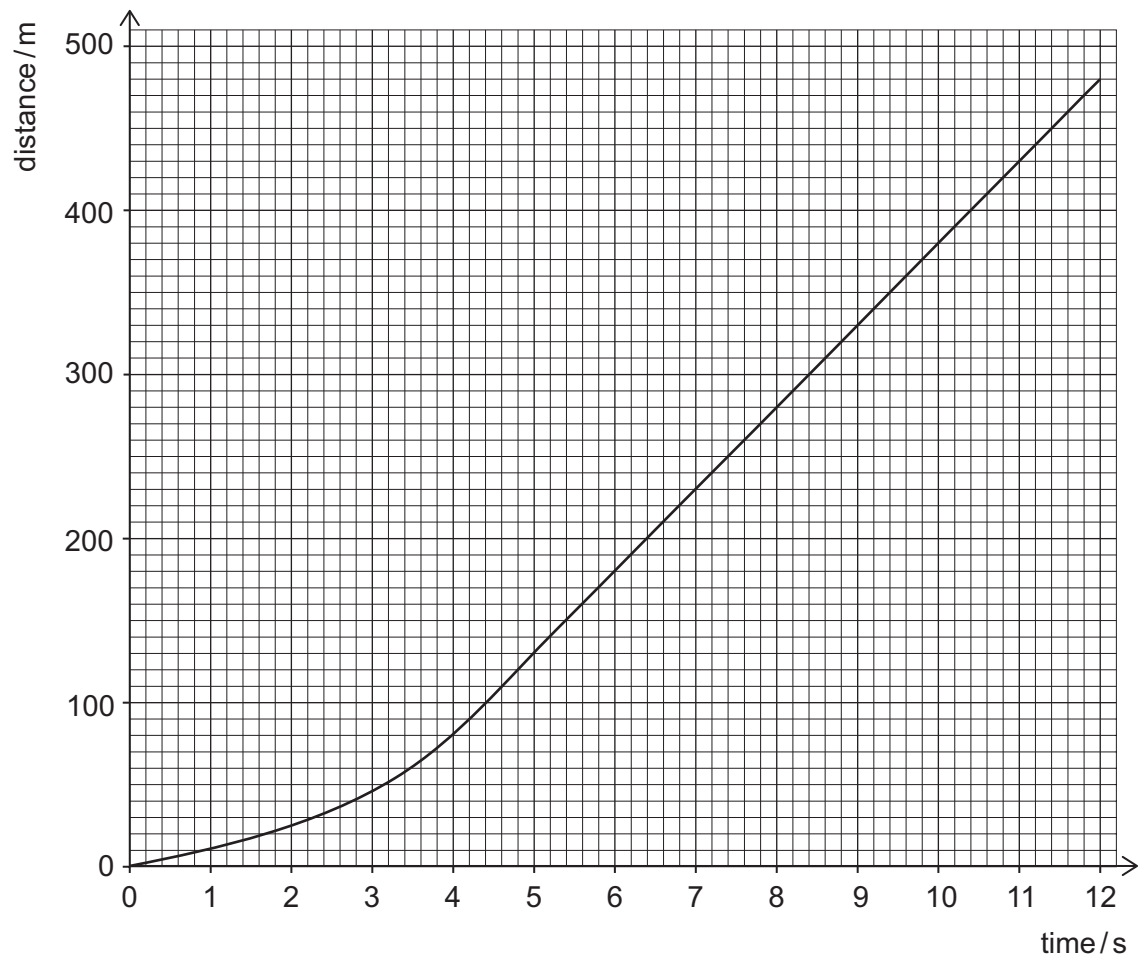

The air resistance  $F$  (in N) acting on the skydiver travelling at velocity  $v$  (in  $\text{m s}^{-1}$ ) is given by the equation

$$F = kv^2$$

where  $k$  (in  $\text{N m}^{-2} \text{s}^2$ ) is a constant.

What is the numerical value of  $k$  for the skydiver?

- A 0.050
- B 0.40
- C 0.63
- D 2.5
- E 20

- 32 A source generates water waves of fixed frequency that have a wavelength of 1.5 cm.

As they cross a boundary into shallower water their frequency does not change, but their speed is reduced by  $18 \text{ cm s}^{-1}$ .

The new wavelength is 1.2 cm.

What is the speed of the waves in the shallower water?

- A  $42 \text{ cm s}^{-1}$   
 B  $50 \text{ cm s}^{-1}$   
 C  $54 \text{ cm s}^{-1}$   
 D  $60 \text{ cm s}^{-1}$   
 E  $72 \text{ cm s}^{-1}$   
 F  $90 \text{ cm s}^{-1}$
- 33 A neutron is absorbed by a uranium-235 ( ${}^{235}_{92}\text{U}$ ) nuclide.

The resulting nuclide undergoes fission to produce a bromine-88 ( ${}^{88}_{35}\text{Br}$ ) nuclide, a lanthanum-145 nuclide and some neutrons.

The lanthanum-145 nuclide is radioactive and emits a beta ( $\beta^-$ ) particle.

How many neutrons are emitted in the fission reaction and how many protons are there in the nuclide formed by the decay of lanthanum-145?

	<i>neutrons</i>	<i>protons</i>
<b>A</b>	2	55
<b>B</b>	2	56
<b>C</b>	2	57
<b>D</b>	2	58
<b>E</b>	3	55
<b>F</b>	3	56
<b>G</b>	3	57
<b>H</b>	3	58



- 34 The diagram shows a circuit containing a battery and three identical resistors X, Y and Z.

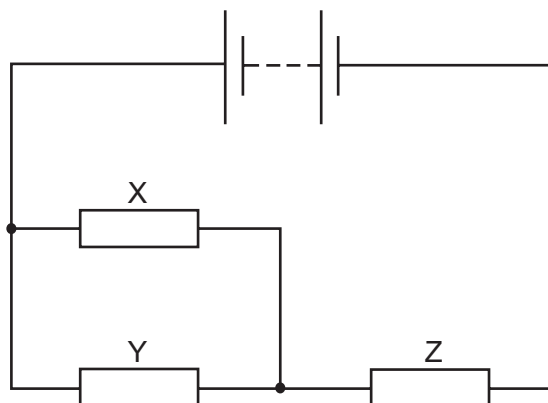

The total power supplied by the battery is 18 W.

What is the power dissipated as heat in resistor X?

- A 1.5 W
- B 2.0 W
- C 3.0 W
- D 4.5 W
- E 6.0 W
- F 8.0 W
- G 12 W

- 35 A filament lamp and a  $0\text{-}10\ \Omega$  variable resistor are connected in series with a power supply of constant voltage.

The graph shows the voltage–current ( $V\text{-}I$ ) characteristic of the filament lamp.

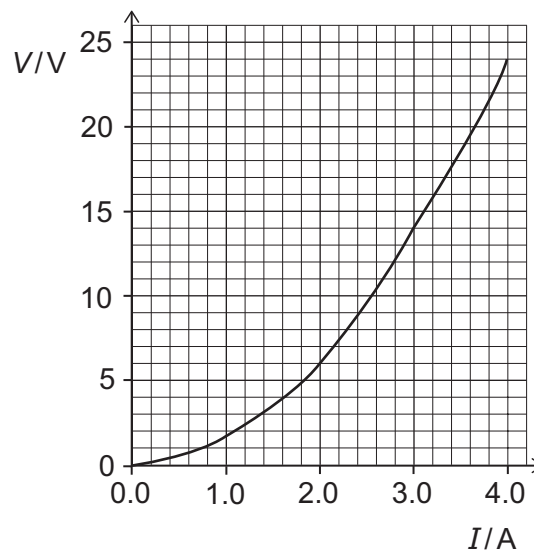

When the resistance of the variable resistor is  $4.0\ \Omega$ , the current in the lamp is  $2.0\ \text{A}$ .

What is the power dissipated in the lamp when the resistance of the variable resistor is zero?

- A 12 W
- B 14 W
- C 16 W
- D 28 W
- E 42 W
- F 96 W

**36** Three detectors X, Y and Z are separated by large distances.

Each of the detectors records a seismic wave from the same earthquake whose epicentre (source) is very close to the surface of the Earth.

The wave travels out from the epicentre at  $4.0 \text{ km s}^{-1}$ .

Detectors X and Y start to detect the wave at the same time, but detector Z starts to detect it one minute later.

Which of the following statements **must** be correct?

- 1** The epicentre is at the midpoint of the line XY.
  - 2** Z is equidistant from X and Y.
  - 3** Z is no more than 240 km away from X and from Y.
- 
- A** none of them
  - B** 1 only
  - C** 2 only
  - D** 3 only
  - E** 1 and 2 only
  - F** 1 and 3 only
  - G** 2 and 3 only
  - H** 1, 2 and 3

**BLANK PAGE**

**PART C Chemistry**

- 37 Which row in the following table gives the numbers of protons, neutrons and electrons in  ${}^{64}_{29}\text{Cu}^{2+}$  ?

	<i>number of protons</i>	<i>number of neutrons</i>	<i>number of electrons</i>
<b>A</b>	27	33	27
<b>B</b>	27	35	29
<b>C</b>	29	35	27
<b>D</b>	29	35	29
<b>E</b>	31	33	29
<b>F</b>	31	35	29

- 38 The following exothermic reaction reaches equilibrium at room temperature.

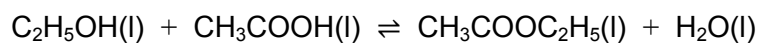

Which of the following changes, when applied independently, will alter the position of the equilibrium?

- 1 increasing the temperature by 25 °C
  - 2 adding 20 cm<sup>3</sup> of water to the equilibrium mixture
  - 3 adding a catalyst
  - 4 adding an extra 0.5 mol of ethanol (C<sub>2</sub>H<sub>5</sub>OH)
- A** 1 only
- B** 1 and 3 only
- C** 1, 2 and 4 only
- D** 2 and 4 only
- E** 1, 2, 3 and 4

39 What is the overall process that takes place at the cathode (negative electrode) in the electrolysis of dilute aqueous sodium sulfate?

- A  $2\text{H}^+ + 2\text{e}^- \rightarrow \text{H}_2$   
 B  $2\text{O}^{2-} \rightarrow \text{O}_2 + 4\text{e}^-$   
 C  $4\text{OH}^- \rightarrow \text{O}_2 + 2\text{H}_2\text{O} + 4\text{e}^-$   
 D  $\text{Na}^+ + \text{e}^- \rightarrow \text{Na}$   
 E  $\text{SO}_4^{2-} \rightarrow \text{SO}_2 + \text{O}_2 + 2\text{e}^-$

40 A mass spectrum of a sample of element X with atomic number 5 is shown.

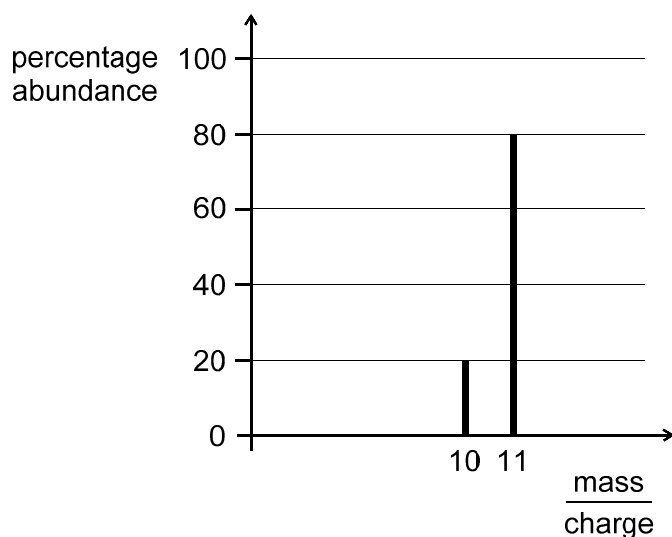

Using the data, which row in the following table best describes the position of X in the Periodic Table and the relative atomic mass of this sample of X?

	<i>Period</i>	<i>Group</i>	<i>relative atomic mass</i>
<b>A</b>	1	15	10.2
<b>B</b>	1	15	10.8
<b>C</b>	2	13	10.2
<b>D</b>	2	13	10.8
<b>E</b>	3	2	10.2
<b>F</b>	3	2	10.8

- 41 The gases nitrogen, oxygen and argon can be separated from liquefied air by fractional distillation.

Given the data in the table, in which order would the gases be collected?

	<i>melting point / °C</i>	<i>boiling point / °C</i>
nitrogen	-210	-196
oxygen	-218	-183
argon	-189	-186

- A nitrogen, oxygen, argon  
 B nitrogen, argon, oxygen  
 C oxygen, nitrogen, argon  
 D oxygen, argon, nitrogen  
 E argon, nitrogen, oxygen  
 F argon, oxygen, nitrogen
- 42 Concentrated aqueous sodium chloride was electrolysed. After a few minutes, the remaining electrolyte solution was tested with a pH probe at 25 °C.

The gases produced at the electrodes were collected and tested with a colourless aqueous solution of sodium bromide.

Which row in the following table best describes the observations in these tests?

	<i>pH of the remaining solution</i>	<i>test of gas from anode (positive electrode)</i>	<i>test of gas from cathode (negative electrode)</i>
<b>A</b>	2	no observable change	no observable change
<b>B</b>	2	no observable change	orange solution forms
<b>C</b>	7	orange solution forms	no observable change
<b>D</b>	7	orange solution forms	orange solution forms
<b>E</b>	12	orange solution forms	no observable change
<b>F</b>	12	no observable change	orange solution forms



- 43 The following equations show the main reactions that take place in a blast furnace during the extraction of iron and the removal of the impurities:

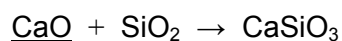
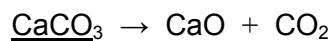
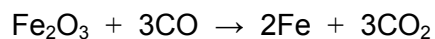
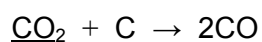
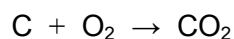

Which row in the following table correctly identifies whether the underlined substance is oxidised, or reduced, or neither?

	$\text{CO}_2$	$\text{CaCO}_3$	$\text{CaO}$
<b>A</b>	oxidised	reduced	neither
<b>B</b>	oxidised	neither	neither
<b>C</b>	oxidised	reduced	oxidised
<b>D</b>	oxidised	neither	oxidised
<b>E</b>	reduced	reduced	neither
<b>F</b>	reduced	neither	neither
<b>G</b>	reduced	reduced	oxidised
<b>H</b>	reduced	neither	oxidised

- 44 X, Y and Z have the **same** electron configuration.

X is an atom, Y is a monatomic anion and Z is a monatomic cation.

Which of the following statements is **always** correct?

- A** Anion Y has fewer protons than atom X.
- B** Cation Z has more electrons than protons.
- C** X, Y and Z are in the same group of the Periodic Table.
- D** X, Y and Z have consecutive atomic numbers.
- E** X, Y and Z have the same mass number.

- 45 In the Contact process, sulfur dioxide reacts with oxygen to make sulfur trioxide in a reversible reaction.

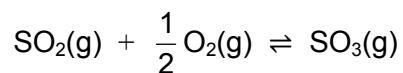

When 5.00 mol of  $\text{SO}_2$  and 11.0 mol of  $\text{O}_2$  are allowed to reach equilibrium at  $450^\circ\text{C}$ , 80.0% of the  $\text{SO}_2$  is converted to  $\text{SO}_3$ .

What is the volume of the resulting mixture?

(Assume that temperature and pressure are constant, and that at this temperature the volume of one mole of gas is  $60.0 \text{ dm}^3$ .)

- A  $240 \text{ dm}^3$
- B  $336 \text{ dm}^3$
- C  $600 \text{ dm}^3$
- D  $720 \text{ dm}^3$
- E  $840 \text{ dm}^3$
- F  $960 \text{ dm}^3$

- 46** The non-metallic element phosphorus forms two stable chlorides:  $\text{PCl}_3$  (boiling point  $76^\circ\text{C}$ ) and  $\text{PCl}_5$  (boiling point  $161^\circ\text{C}$ ).

Which of the following statements explain(s) the difference in boiling points?

- 1** There are more covalent bonds in  $\text{PCl}_5$  so more energy is required to break them.
- 2** The forces between the molecules in liquid  $\text{PCl}_5$  are stronger.
- 3** The covalent bonds in  $\text{PCl}_3$  are weaker so less energy is required to break them.

**A** none of them

**B** 1 only

**C** 2 only

**D** 3 only

**E** 1 and 2 only

**F** 1 and 3 only

**G** 2 and 3 only

**H** 1, 2 and 3

- 47** A student calculated the mass of anhydrous copper(II) sulfate ( $\text{CuSO}_4$ ) required to make  $250\text{ cm}^3$  of an aqueous solution of concentration  $0.200\text{ mol dm}^{-3}$ .

However, the student mistakenly made the solution using the same mass of hydrated copper(II) sulfate ( $\text{CuSO}_4 \cdot 5\text{H}_2\text{O}$ ) instead.

What is the concentration, in  $\text{mol dm}^{-3}$ , of the solution made with the hydrated copper(II) sulfate?

( $A_r$  values:  $\text{Cu} = 64$ ;  $\text{S} = 32$ ;  $\text{O} = 16$ ;  $\text{H} = 1.0$ )

**A**  $0.128\text{ mol dm}^{-3}$

**B**  $0.160\text{ mol dm}^{-3}$

**C**  $0.180\text{ mol dm}^{-3}$

**D**  $0.200\text{ mol dm}^{-3}$

**E**  $0.223\text{ mol dm}^{-3}$

**F**  $0.313\text{ mol dm}^{-3}$

**48** Bromine is an element in Group 17 of the Periodic Table.

Which of the following statements is/are correct about the element bromine?

- 1** Bromine will oxidise chloride ions in aqueous solution to form chlorine.
- 2** Bromine has a lower boiling point than chlorine.
- 3** Bromine reacts with calcium (Group 2) to form a compound containing 80% bromine by mass.

( $A_r$  values: Cl = 35.5; Ca = 40; Br = 80)

- A** none of them
- B** 1 only
- C** 2 only
- D** 3 only
- E** 1 and 2 only
- F** 1 and 3 only
- G** 2 and 3 only
- H** 1, 2 and 3

- 49 Paper chromatography was used to separate three mixtures of amino acids. The mixtures were labelled P, Q and R.

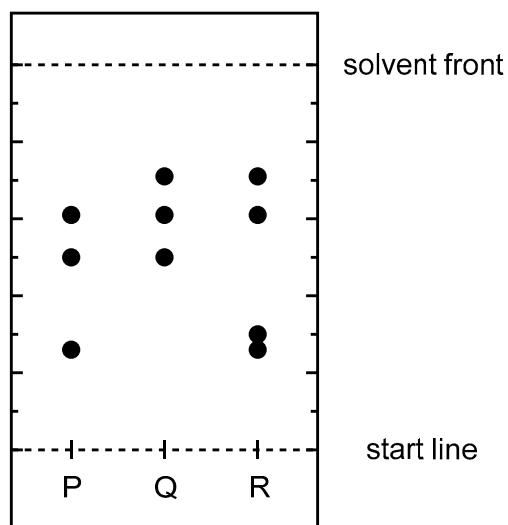

Each mixture contains some of the five amino acids in the following table. The  $R_f$  values were measured for each amino acid with the solvent used to produce the chromatogram.

<i>amino acid</i>	$R_f$ value
asparagine	0.50
glutamic acid	0.30
glycine	0.26
leucine	0.71
valine	0.61

Which of the following statements is/are correct?

- 1 Mixture P contains valine and glycine.
  - 2 Leucine is found in all three mixtures.
  - 3 Glutamic acid is the least mobile amino acid with this solvent.
  - 4 Mixtures P and Q both contain asparagine.
- A 1 and 2 only  
 B 1 and 4 only  
 C 2 and 3 only  
 D 3 only  
 E 4 only

- 50 Dilute hydrochloric acid and magnesium were mixed and the total volume of gas released was measured over time.

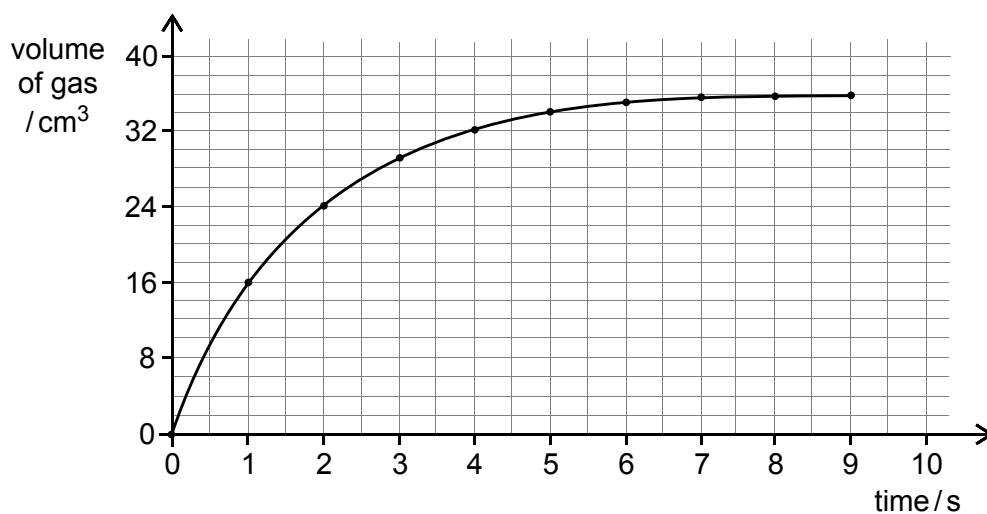

What is the average rate of reaction, in  $\text{g s}^{-1}$ , with respect to the magnesium over the first **two** seconds?

( $A_r$  value:  $\text{Mg} = 24$ . Assume that the volume of one mole of gas is  $24 \text{ dm}^3$ .)

- A  $0.012 \text{ g s}^{-1}$
- B  $0.024 \text{ g s}^{-1}$
- C  $0.048 \text{ g s}^{-1}$
- D  $12 \text{ g s}^{-1}$
- E  $24 \text{ g s}^{-1}$
- F  $48 \text{ g s}^{-1}$

- 51 Copper can react with concentrated nitric acid to form the gas nitrogen monoxide.

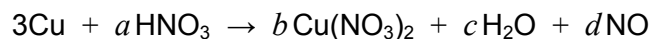

What is the value of  $a$  when the equation is balanced?

- A 6
  - B 7
  - C 8
  - D 9
  - E 10
  - F 11
  - G 12
- 52 A small amount of a solid mixture, containing calcium carbonate and an inert substance, was added to  $50.00\text{ cm}^3$  dilute hydrochloric acid of concentration  $0.1000\text{ mol dm}^{-3}$ .



After all of the calcium carbonate had reacted, the solution was heated to drive off the carbon dioxide.

The resulting solution was neutralised by  $12.50\text{ cm}^3$  of  $0.1000\text{ mol dm}^{-3}$  sodium hydroxide solution.

What was the mass of calcium carbonate in the mixture added to the hydrochloric acid?

( $M_r$  value:  $\text{CaCO}_3 = 100.0$ )

- A 0.06250 g
- B 0.1250 g
- C 0.1875 g
- D 0.3750 g
- E 0.6250 g
- F 0.7500 g

- 53** 2.80 g of lithium metal is placed in a closed system with 1.20 dm<sup>3</sup> of pure oxygen gas (volume measured at room temperature and pressure).

If a complete reaction occurs between the lithium and the oxygen, what is the maximum mass of lithium oxide that can be formed?

( $A_r$  values: Li = 7; O = 16. Assume that one mole of gas occupies 24.0 dm<sup>3</sup> at room temperature and pressure.)

- A** 1.50 g
  - B** 3.00 g
  - C** 3.90 g
  - D** 4.60 g
  - E** 6.00 g
  - F** 12.0 g
  - G** 15.6 g
- 54** The following reaction between nitrogen oxide and oxygen releases 116 kJ of energy as heat for each mole of oxygen that reacts.

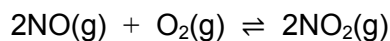

An excess of NO and  $y$  moles of oxygen are mixed in a sealed container. The reaction reaches equilibrium in one hour.

At equilibrium, there are  $z$  moles of NO<sub>2</sub>.

Assume that the pressure is constant throughout the experiment.

How much heat will be released over this hour?

- A** 0 kJ
- B** 58 $y$  kJ
- C** 116 $y$  kJ
- D** 232 $y$  kJ
- E** 58 $z$  kJ
- F** 116 $z$  kJ
- G** 232 $z$  kJ



**PART D Biology**

- 55 The graph shows how four variables change with the distance down a river, after a source of pollution flowed in.

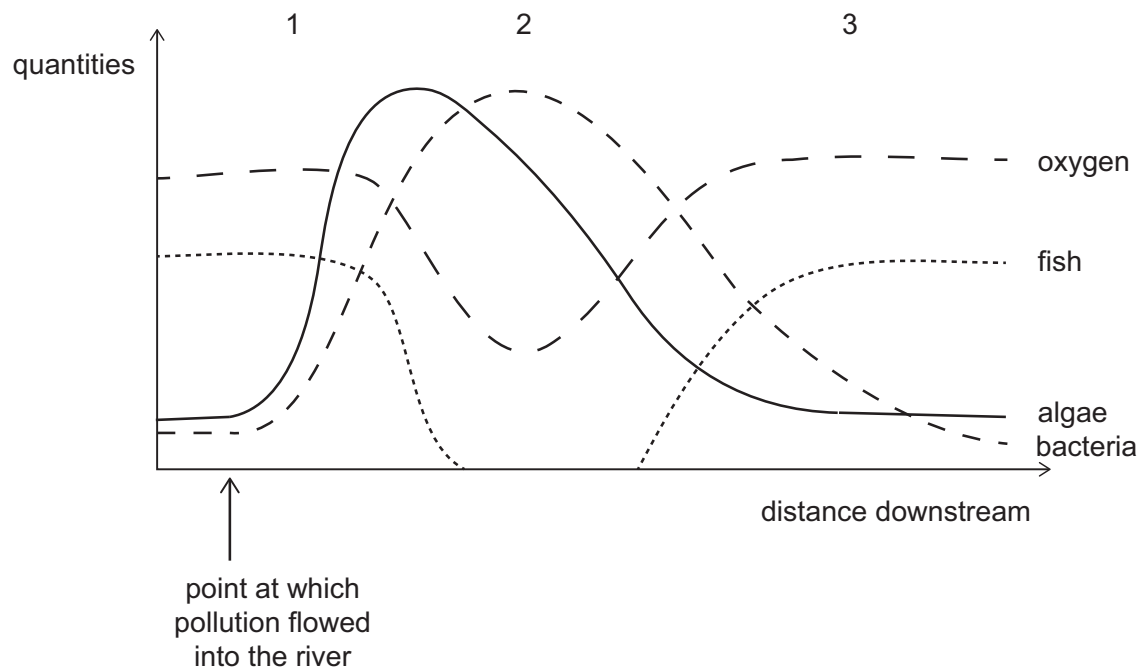

Which indicator species could be expected to be found in large numbers at 1, 2 and 3?

	1	2	3
<b>A</b>	bloodworm	bloodworm	bloodworm
<b>B</b>	bloodworm	bloodworm	stonefly
<b>C</b>	bloodworm	stonefly	bloodworm
<b>D</b>	bloodworm	stonefly	stonefly
<b>E</b>	stonefly	bloodworm	bloodworm
<b>F</b>	stonefly	bloodworm	stonefly
<b>G</b>	stonefly	stonefly	bloodworm
<b>H</b>	stonefly	stonefly	stonefly

- 56** Sickle cell anaemia is a recessive genetic condition that results in abnormally-shaped red blood cells due to the production of a faulty type of haemoglobin. Children born with sickle cell anaemia rarely live to adulthood without significant medical intervention. Carriers, who only have one copy of the sickle cell allele, have greater resistance to the disease malaria than people with two copies of the allele for normal functional haemoglobin.

Using this information, which of the following statements is/are correct?

- 1** People with sickle cell anaemia would have reduced anaerobic respiration in their muscle cells.
  - 2** In areas with malaria the percentage of people surviving with sickle cell anaemia increases.
  - 3** In parts of Africa where malaria is more common you would expect to find more people with a sickle cell allele.
- A** none of them
- B** 1 only
- C** 2 only
- D** 3 only
- E** 1 and 2 only
- F** 1 and 3 only
- G** 2 and 3 only
- H** 1, 2 and 3

57 A student studied this photograph of part of an organ.

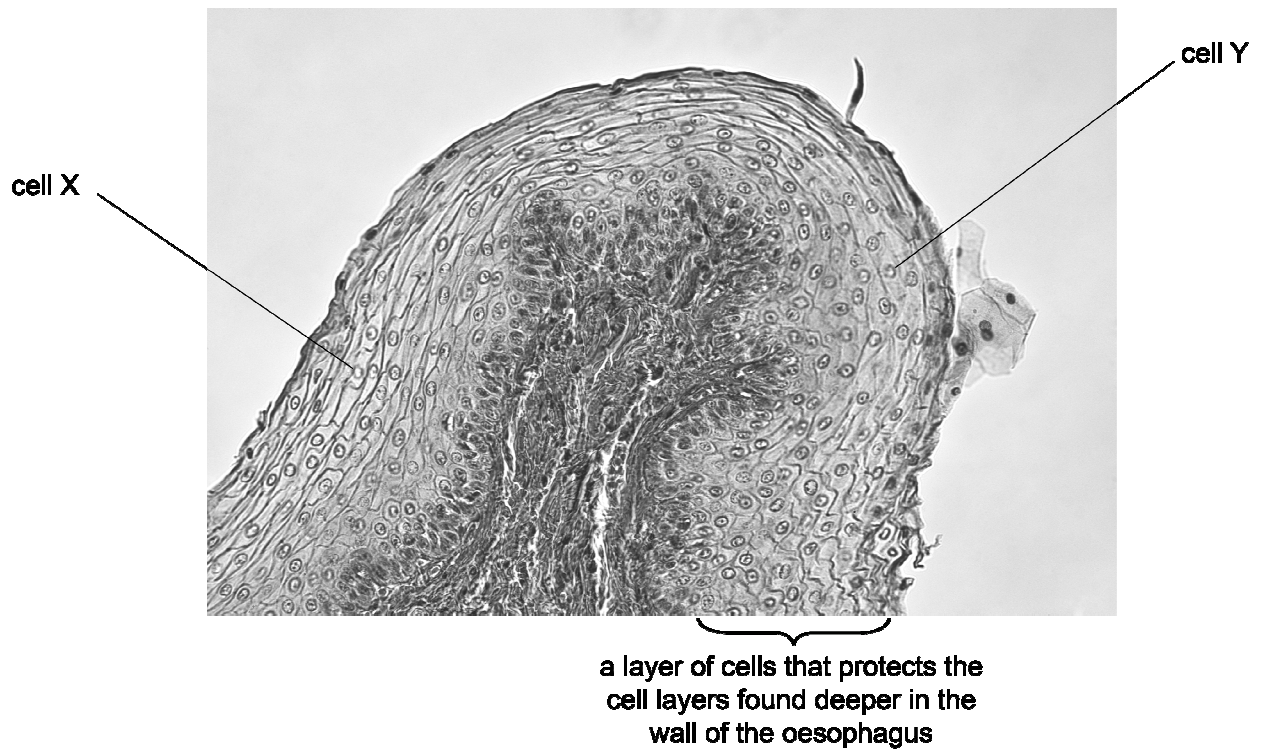

The student drew the following conclusions about the two cells labelled X and Y.

- 1 Both cells X and Y are found in the same tissue.
- 2 Both cells X and Y were produced by mitosis.
- 3 Both cells X and Y have a cell wall.

Which of these conclusions is/are correct?

- A none of them
- B 1 only
- C 2 only
- D 3 only
- E 1 and 2 only
- F 1 and 3 only
- G 2 and 3 only
- H 1, 2 and 3

**58** A student investigated the tadpole population in a large pond.

A net with a rectangular opening measuring  $0.1\text{ m} \times 0.2\text{ m}$  was swept through the water for a fixed distance of 1 m. This was repeated 10 times.

All the sweeps were made at the edge of the pond as the student had no waders or boat.

The number of tadpoles in each sweep was recorded in the table.

<i>sweep number</i>	1	2	3	4	5	6	7	8	9	10
<i>number of tadpoles</i>	20	12	32	0	4	8	4	8	12	20

The student made the following statements.

- 1 Each sweep sampled  $0.02\text{ m}^3$  of water.
- 2 The frequency of occurrence of the tadpoles was 90%.
- 3 An accurate estimate of the population size of tadpoles in the pond could be calculated using this data if the total volume of water was known.

Which of the statements about the investigation is/are correct?

- A none of them
- B 1 only
- C 2 only
- D 3 only
- E 1 and 2 only
- F 1 and 3 only
- G 2 and 3 only
- H 1, 2 and 3

**59** A breeding experiment was carried out using rats.

A pair of rats has eight offspring per litter. The offspring breed freely amongst each other within the same generation. Each female is only allowed to have one litter of eight.

The expected ratio of male to female offspring in this breeding population is the same in rats as in humans, and is seen in every generation.

In the 4<sup>th</sup> generation of offspring, how many individuals would be expected to have the XY genotype?

- A** 16
- B** 32
- C** 64
- D** 128
- E** 256
- F** 512
- G** 1024

- 60 The diagram shows four steps in the process of human sperm production. For each step only one complete division takes place.

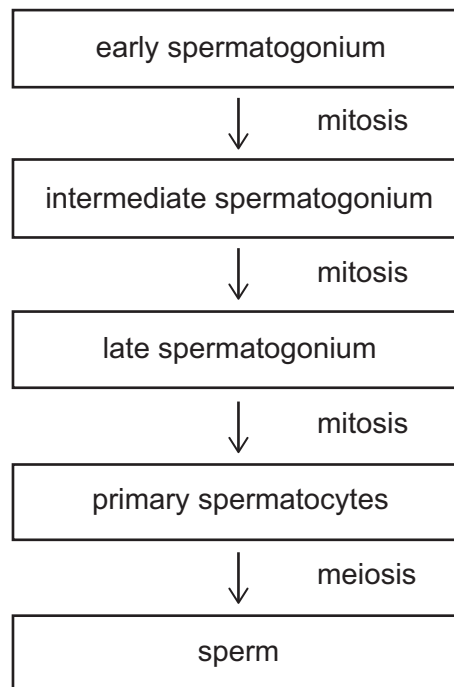

Assuming no mutations and that all of the cells survive, what will be the maximum number of haploid cells originating from a single early spermatogonium?

- A 1
- B 2
- C 8
- D 16
- E 32
- F 64

**61** Which of the following conditions is/are required by the cells near the tip of a plant shoot in order for the tip to grow towards light from one direction?

- 1** sufficient glucose
- 2** uneven distribution of plant hormone
- 3** sufficient oxygen

- A** none of them
- B** 1 only
- C** 2 only
- D** 3 only
- E** 1 and 2 only
- F** 1 and 3 only
- G** 2 and 3 only
- H** 1, 2 and 3

**62** A cell from the epithelium of an animal was removed. The cytoplasm of this cell can be considered as a 2% sugar solution. The living cell was placed in a 4% sugar solution.

Which of the following statements is/are correct?

- 1** At equilibrium, the sugar concentration in the cell was 6%.
- 2** Water continued to move across the cell membrane after equilibrium was reached.
- 3** Osmosis was most rapid when the cell was first placed in the solution.

- A** none of them
- B** 1 only
- C** 2 only
- D** 3 only
- E** 1 and 2 only
- F** 1 and 3 only
- G** 2 and 3 only
- H** 1, 2 and 3



- 63** A piece of DNA is made up of two complementary strands, each 25 bases long.  
14% of the bases are adenine.

Which two statements are correct?

- 1** Adenine and cytosine together make up 25 bases.
  - 2** Adenine and guanine together make up 50% of the bases.
  - 3** There are 14 thymine bases present.
  - 4** 36 of the bases are guanine.
- 
- A** 1 and 2 only
  - B** 1 and 3 only
  - C** 1 and 4 only
  - D** 2 and 3 only
  - E** 2 and 4 only
  - F** 3 and 4 only

- 64** In a laboratory, the activity of two lipase enzymes on the same type of lipid was studied. One lipase enzyme was produced from a mutation in the gene that coded for the original enzyme. The mutation occurred in the sequence for three adjacent amino acids called serine, aspartic acid and histidine. The graph shows the results of this study.

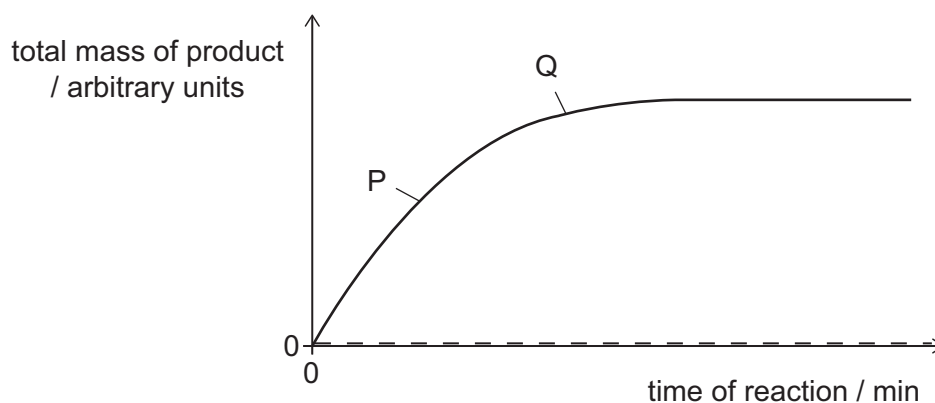
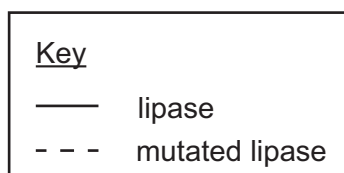

Which of the following statements is/are correct?

- 1 The serine, aspartic acid and histidine amino acids could be in the active site of the enzyme.
  - 2 All mutations affecting the region coding for serine, aspartic acid and histidine amino acids will be expected to have the same effect.
  - 3 At point Q on the graph, the pH of the reaction mixture will be higher than at P.
- A** none of them
- B** 1 only
- C** 2 only
- D** 3 only
- E** 1 and 2 only
- F** 1 and 3 only
- G** 2 and 3 only
- H** 1, 2 and 3

- 65 The family tree shows a family affected by a dominant genetic condition. All people who carry the mutation show symptoms of the condition.

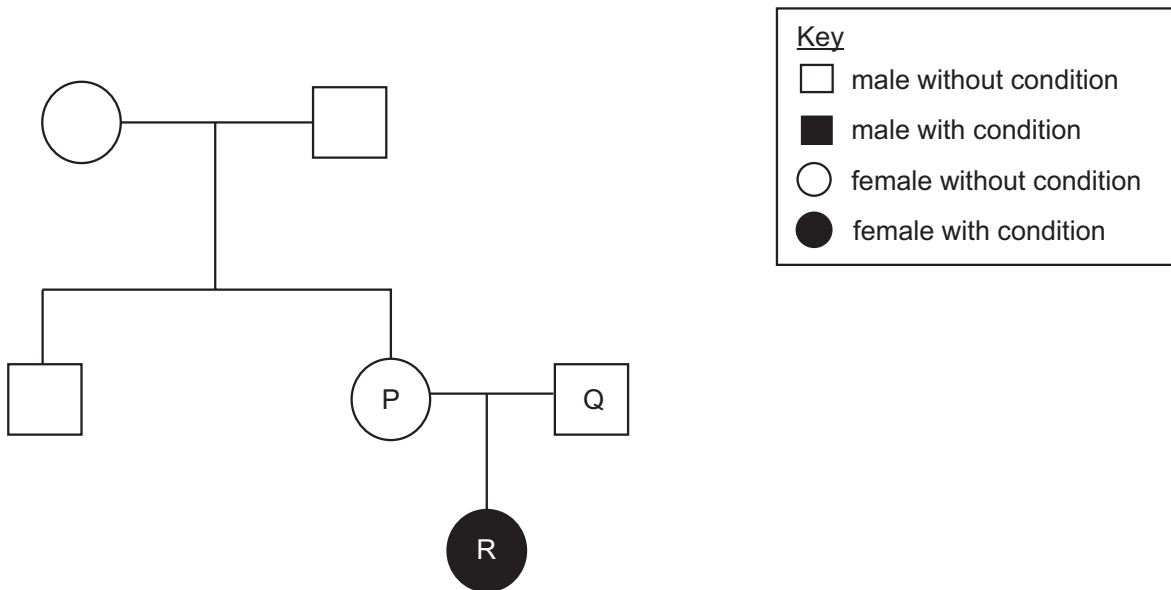

Which of the following statements could explain the presence of the dominant condition in female R?

- 1 The mutation occurs in P.
  - 2 The mutation occurs in Q's father.
  - 3 The mutation occurs in R.
- A** none of them
- B** 1 only
- C** 2 only
- D** 3 only
- E** 1 and 2 only
- F** 1 and 3 only
- G** 2 and 3 only
- H** 1, 2 and 3

**66** Dolly the sheep was born in 1996. She was unusual because she had no biological father.

The diagram shows how she was produced.

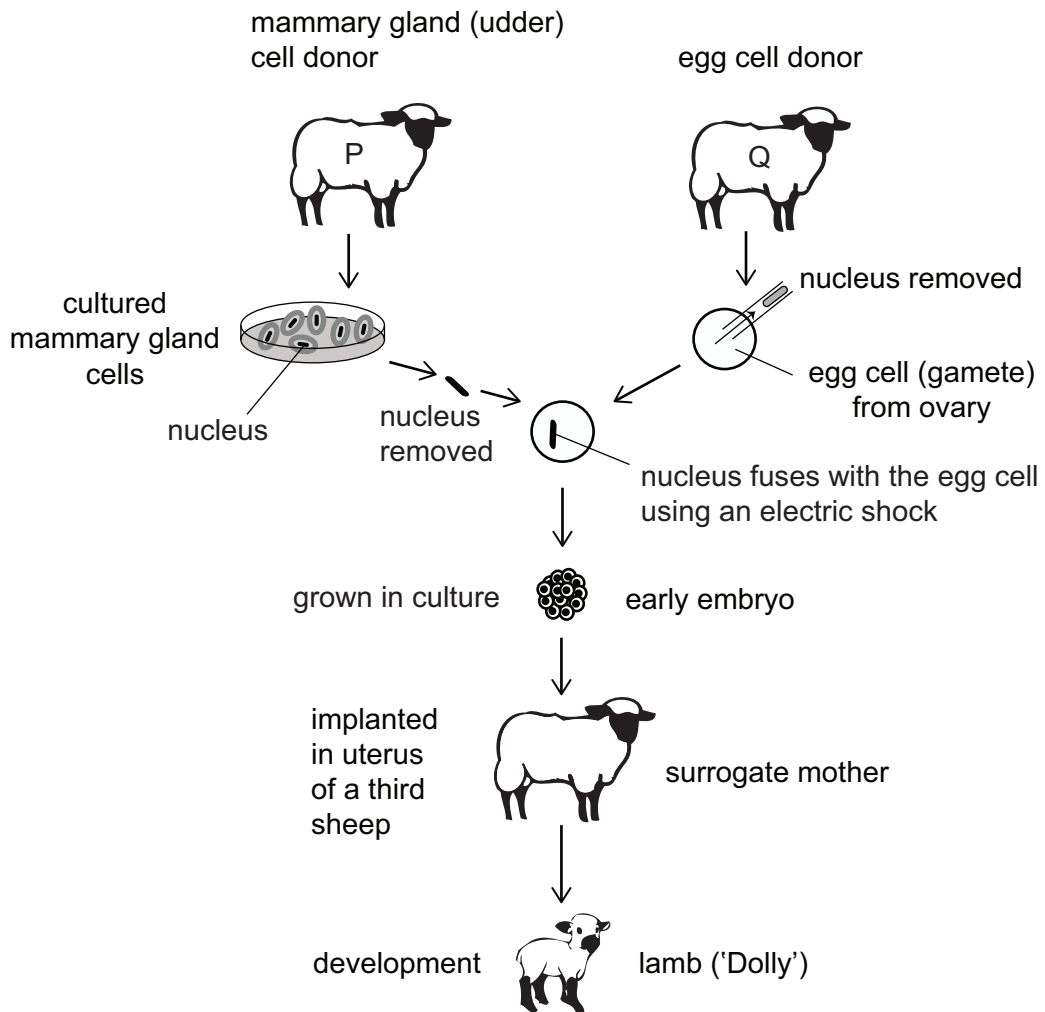

Which of the following processes had to occur to produce Dolly?

- 1 genetic engineering
  - 2 mitosis
  - 3 meiosis
  - 4 differentiation
- A** 1 and 2 only
- B** 2 and 3 only
- C** 1, 2 and 4 only
- D** 1, 3 and 4 only
- E** 2, 3 and 4 only

- 67** A student investigated the rate of oxygen bubble release from a pondweed plant at different temperatures. The rates are shown below, with two sections of the graph marked X and Y. In each investigation all other factors were kept constant.

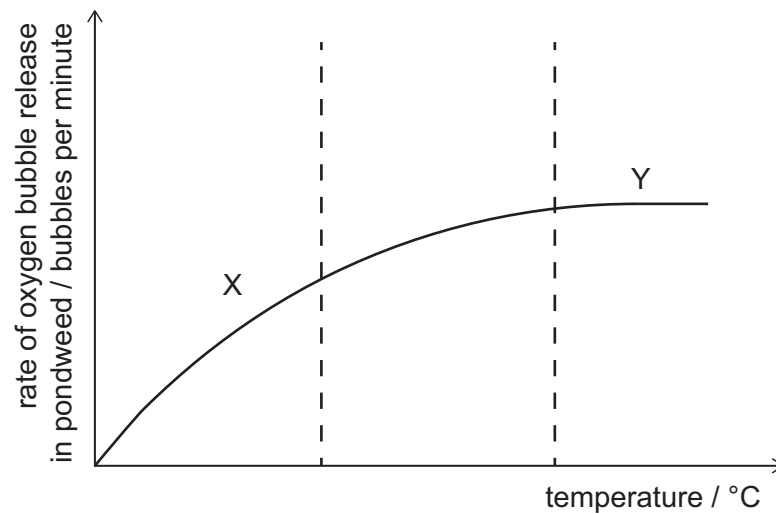

Which of the following statements about sections X and Y is/are correct?

- 1** In section X, the kinetic energy of the reaction molecules is increasing with increasing temperature.
  - 2** In section Y, temperature is the factor which limits that rate of oxygen production.
  - 3** In section Y, the plant's enzymes may have denatured.
  - 4** Section Y represents the plant's maximum possible rate of oxygen production under any conditions.
- A** 1 only
- B** 2 only
- C** 3 only
- D** 4 only
- E** 1 and 2 only
- F** 1 and 4 only
- G** 2 and 3 only
- H** 3 and 4 only

- 68 The diagram below shows a circular piece of bacterial DNA called a plasmid that has been made recombinant by the insertion of a plant gene for herbicide resistance.

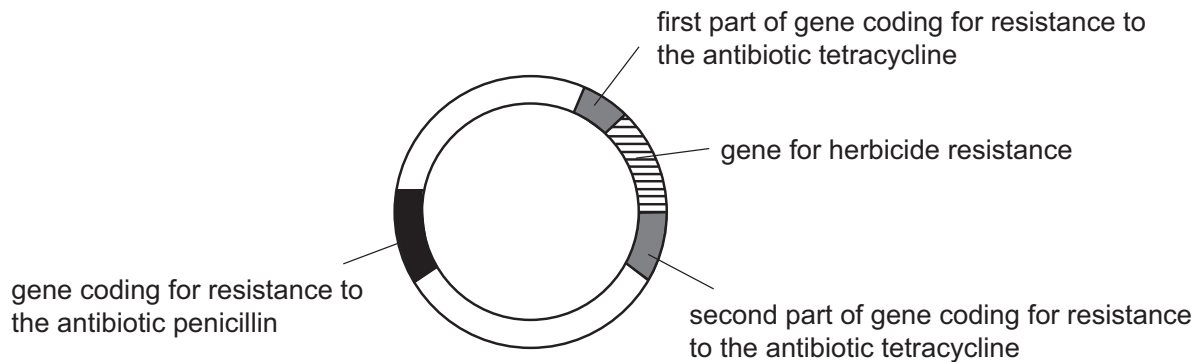

Bacteria containing only the recombinant plasmid had to be identified from bacteria that contained only the original plasmid. The original plasmid contained a gene coding for resistance to the antibiotic penicillin and a gene coding for resistance to the antibiotic tetracycline.

These bacteria were grown on two sets of agar plates. One set used agar that contained the antibiotic penicillin and the other set used agar that contained the antibiotic tetracycline.

Which row in the table correctly shows the growth of these bacteria on the two sets of agar?

	<i>bacteria containing only</i>	<i>growth on agar containing penicillin</i>	<i>growth on agar containing tetracycline</i>
<b>A</b>	recombinant plasmid	yes	yes
	original plasmid	no	no
<b>B</b>	recombinant plasmid	yes	yes
	original plasmid	yes	no
<b>C</b>	recombinant plasmid	yes	no
	original plasmid	yes	yes
<b>D</b>	recombinant plasmid	no	no
	original plasmid	yes	yes
<b>E</b>	recombinant plasmid	yes	yes
	original plasmid	no	yes
<b>F</b>	recombinant plasmid	no	no
	original plasmid	no	no
<b>G</b>	recombinant plasmid	yes	no
	original plasmid	no	yes

- 69** A student analysed a gene sequence that had been identified in four different types of organism. The gene codes for a functional protein. A section of the gene's DNA is shown below. The rest of the DNA from this gene (not shown) is identical in all four different types of organism.

<i>organism</i>	<i>DNA sequence</i>					
human	ACG	CCT	CGT	CAC	GCT	AAA
oak tree	ACG	GAA	TAT	GTA	GCT	AAA
mushroom	ACG	GAA	CTC	TTA	GCT	AAA
<i>E.coli</i> bacterium	ACG	TAC	GAT	GGG	GCT	AAA

The student then made the following conclusions:

- 1** This gene does not code for chlorophyll.
- 2** This gene may be found in the nucleus or cytoplasm.
- 3** The protein that this gene codes for is likely to be more similar in plants and fungi than in the other organisms.

Which of these conclusions is/are correct?

- A** none of them
- B** 1 only
- C** 2 only
- D** 3 only
- E** 1 and 2 only
- F** 1 and 3 only
- G** 2 and 3 only
- H** 1, 2 and 3

- 70** The graphs represent the changes in the mass of a healthy human body cell and in the mass of the DNA of that cell over time.

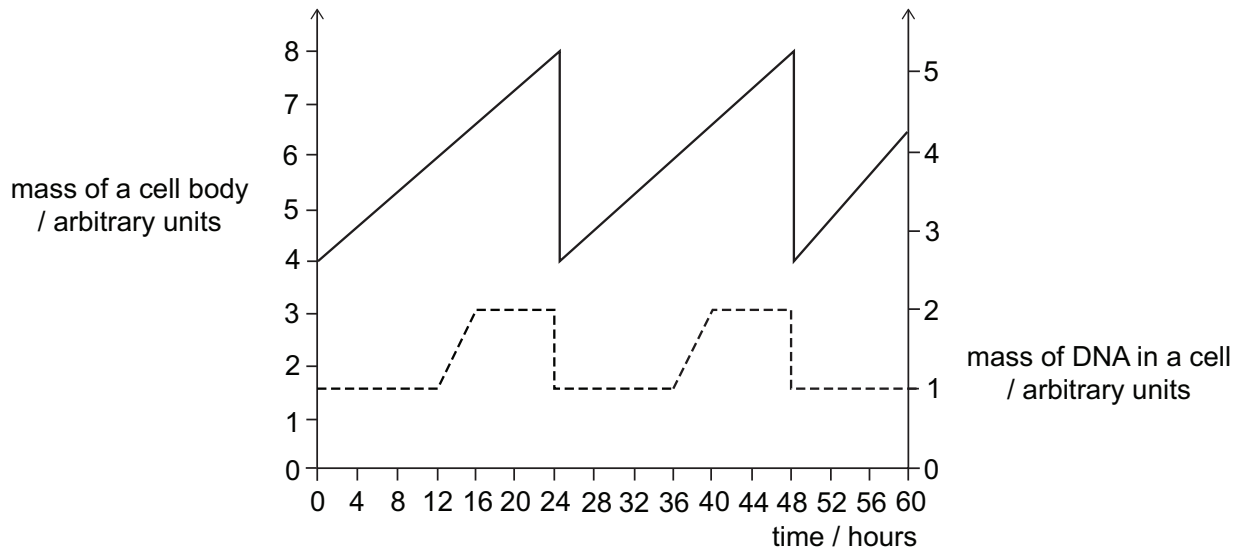
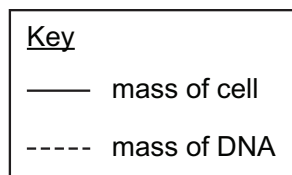

Using the graph, which of the following statements is/are correct?

- 1 Mitosis takes place at 12 and 36 hours.
  - 2 The graph shows two cell divisions.
  - 3 The next cell division should take place at 72 hours.
- A** none of them
- B** 1 only
- C** 2 only
- D** 3 only
- E** 1 and 2 only
- F** 1 and 3 only
- G** 2 and 3 only
- H** 1, 2 and 3



- 71** Bt pesticide is used by farmers to kill insect pests. However, widespread use has resulted in the evolution of resistance to this pesticide. A recessive allele causes resistance.

Scientists have suggested that in areas where the Bt pesticide is used, a small number of fields are left untreated. These untreated fields are known as *refugia*. This method has been shown to slow down evolution of resistance to the pesticide.

Which of the following statements explain why refugia could slow down the evolution of resistance to Bt pesticide?

- 1** When resistant insects breed with pesticide-sensitive insects that do not have the allele for resistance, the offspring produced will be sensitive to the pesticide.
  - 2** When fewer insects are exposed to pesticide, fewer mutations occur that produce alleles for resistance.
  - 3** The refugia help to maintain genetic variation in the population of insect pests.
- A** none of them
- B** 1 only
- C** 2 only
- D** 3 only
- E** 1 and 2 only
- F** 1 and 3 only
- G** 2 and 3 only
- H** 1, 2 and 3

**72** A diploid plant cell divides by mitosis.

After mitosis of this cell, a mutation occurs that changes the genotype of **one** of the daughter cells. This mutant daughter cell produces a non-functional enzyme instead of the functional enzyme produced by the other daughter cell. This mutation has no effect on the phenotype of the plant or the number or length of chromosomes in the plant cell.

Which of the following statements describe the daughter cells after the mutation has occurred?

- 1** The chromosomes in the nucleus of each daughter cell will contain the same genes.
  - 2** Both daughter cells will contain the same alleles for every gene.
  - 3** The sequence of bases along each allele will be the same in each daughter cell.
- A** none of them
- B** 1 only
- C** 2 only
- D** 3 only
- E** 1 and 2 only
- F** 1 and 3 only
- G** 2 and 3 only
- H** 1, 2 and 3

**PART E Advanced Mathematics and Advanced Physics**

**73** Curve  $C$  has equation  $y = 9 - x^2$

Line  $L$  has equation  $y = 5$

What is the area enclosed between  $C$  and  $L$ ?

- A**  $\frac{32}{3}$
- B**  $\frac{62}{3}$
- C**  $\frac{92}{3}$
- D**  $\frac{122}{3}$
- E**  $\frac{152}{3}$

**74** An aircraft moves from rest with uniform acceleration along a horizontal runway. After travelling 1600 m it reaches a speed of  $80 \text{ m s}^{-1}$ .

What is the acceleration of the aircraft?

- A**  $0.025 \text{ m s}^{-2}$
- B**  $0.050 \text{ m s}^{-2}$
- C**  $0.10 \text{ m s}^{-2}$
- D**  $0.50 \text{ m s}^{-2}$
- E**  $2.0 \text{ m s}^{-2}$
- F**  $4.0 \text{ m s}^{-2}$
- G**  $10 \text{ m s}^{-2}$
- H**  $20 \text{ m s}^{-2}$

75 How many solutions of the equation  $2\sin^3\theta = \sin\theta$  lie in the interval  $-\frac{\pi}{2} \leq \theta \leq \pi$  ?

- A 2
- B 3
- C 4
- D 5
- E 6
- F 7

76 The diagram represents a mass that is moving in a straight line at constant speed up a slope of constant gradient.

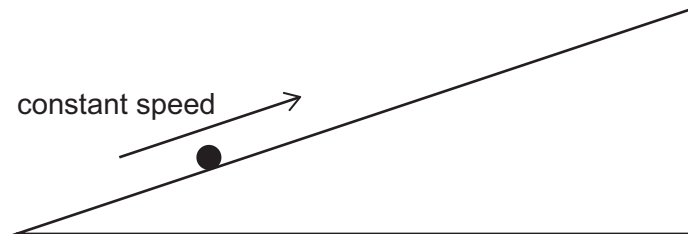

Which statement about the forces acting on the mass **must** be correct?

- A All the forces acting on the mass are equal in magnitude.
- B Only three forces act on the mass.
- C The force of friction on the mass is equal to the driving force.
- D The weight of the mass acts in the opposite direction to the contact force.
- E There is no air resistance acting on the mass.
- F There is no resultant force acting on the mass.

- 77 The line  $y = x + k$ , where  $k$  is a constant, is a tangent to the curve  $y = 3x^2 - 2x + 1$

What is the value of  $k$ ?

- A -2
- B -1
- C  $\frac{1}{4}$
- D  $\frac{1}{3}$
- E  $\frac{1}{2}$
- F  $\frac{3}{4}$
- G 1
- H 2

- 78 The diagram shows four objects W, X, Y and Z, of masses 3.0 kg, 4.0 kg, 6.0 kg and 2.0 kg respectively, connected by light, inextensible rods.

The objects are pulled along a smooth, horizontal surface by a constant force of 30 N in the direction indicated.



What is the tension in the rod connecting X and Y?

- A 8.0 N
- B 10 N
- C 12 N
- D 14 N
- E 16 N

79 In a particular arithmetic progression:

- the 13<sup>th</sup> term is six times the 1<sup>st</sup> term
- the 11<sup>th</sup> term is 1 less than twice the 5<sup>th</sup> term

What is the 3<sup>rd</sup> term of the progression?

- A -14.5  
 B -11  
 C  $\frac{29}{19}$   
 D 3.5  
 E 11  
 F 14.5

80 An object of mass 40 kg is placed on a uniform, horizontal plank of mass 10 kg between two supports X and Y as shown in the diagram.

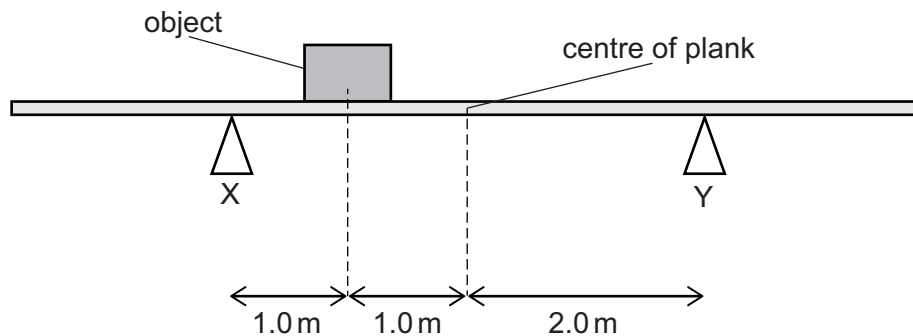

What is the contact force at X?

(gravitational field strength =  $10 \text{ N kg}^{-1}$ )

- A 15 N  
 B 35 N  
 C 150 N  
 D 250 N  
 E 300 N  
 F 350 N  
 G 375 N

81 Evaluate

$$\log_2\left(\frac{5}{4}\right) + \log_2\left(\frac{6}{5}\right) + \log_2\left(\frac{7}{6}\right) + \dots + \log_2\left(\frac{64}{63}\right)$$

- A -2
- B 3
- C 4
- D 6
- E  $\log_2(3!)$
- F  $\log_2 60$

82 An object X of mass 2.0 kg is initially moving at a speed of  $4.5 \text{ m s}^{-1}$  on a smooth, horizontal surface.

A 5.0 N force is applied to X in the direction of its motion for 3.0 seconds.

A short time later it collides head on with, and sticks to, a stationary object Y of mass 3.0 kg.

What is the speed of X and Y as they move off together after the collision?

- A  $1.8 \text{ m s}^{-1}$
- B  $3.0 \text{ m s}^{-1}$
- C  $3.6 \text{ m s}^{-1}$
- D  $4.8 \text{ m s}^{-1}$
- E  $5.4 \text{ m s}^{-1}$



**83** Circle  $C$  has equation  $(x + 3)^2 + (y - 2)^2 = 5$

The length of the tangent from the circle  $C$  to the point  $P$  is  $5\sqrt{3}$

What is the shortest distance from  $P$  to  $C$ ?

- A**  $5\sqrt{3}$
- B**  $5\sqrt{3} + \sqrt{5}$
- C**  $3\sqrt{5}$
- D** 5
- E** 10

- 84** Two solid spheres X and Y have masses  $m$  and  $2m$  respectively. They travel in opposite directions towards each other along the same line with speeds  $v$  and  $2v$  respectively and collide head on.

The graph shows the variation of velocity with time for sphere X before, during, and after the collision.

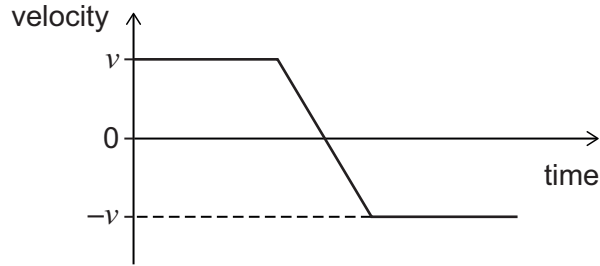

Which sketch shows the variation of velocity with time for sphere Y?

**A**

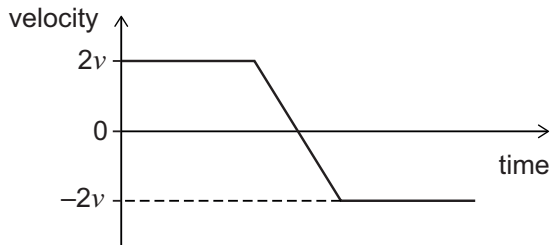

**B**

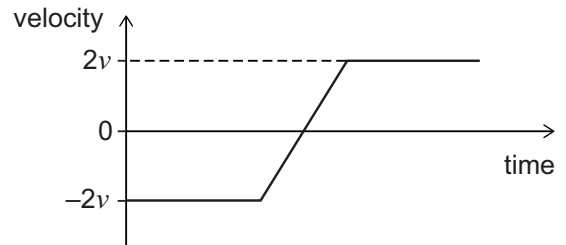

**C**

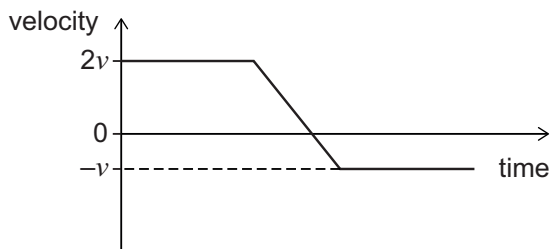

**D**

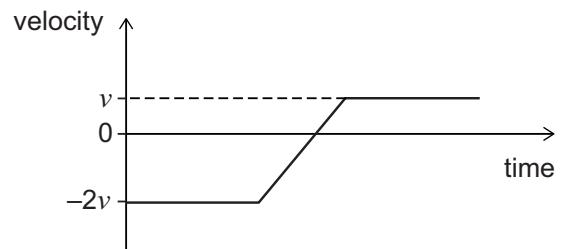

**E**

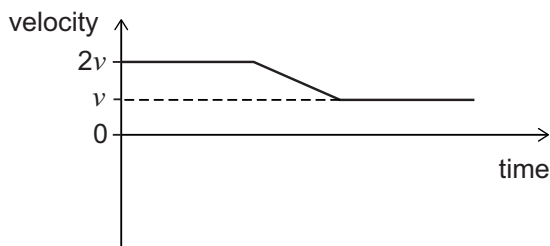

**F**

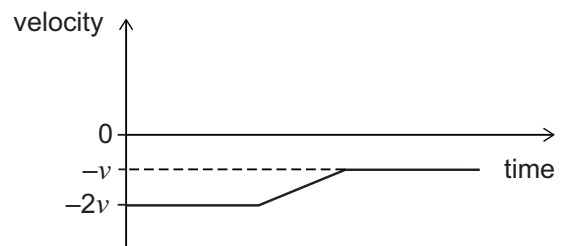

- 85 What is the coefficient of  $x^3$  in the expansion of  $(1 - 2x)^5(1 + 2x)^5$ ?
- A -6400  
B -640  
C -80  
D 0  
E 80  
F 800  
G 960

- 86 A metal ball suspended from a steel cable is held at rest by a horizontal force  $P$ . The cable makes an angle of  $30^\circ$  to the vertical as shown in the diagram. The cable exerts a force  $T$  on the ball.

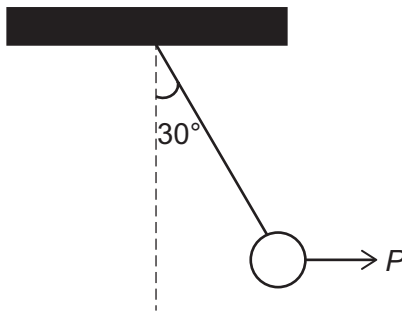

What is the magnitude of  $P$ ?

- A  $\frac{T}{2}$   
B  $T$   
C  $2T$   
D  $\frac{T}{\sqrt{2}}$   
E  $\frac{T}{\sqrt{3}}$   
F  $\frac{2T}{\sqrt{3}}$   
G  $\frac{\sqrt{3}T}{2}$

87 Given that

$$\int_0^2 x^m dx = \frac{16\sqrt{2}}{7}$$

and

$$\int_0^2 x^{m+1} dx = \frac{32\sqrt{2}}{9}$$

what is the value of  $m$ ?

**A**  $-\frac{11}{2}$

**B**  $-\frac{9}{2}$

**C**  $-\frac{22}{29}$

**D**  $\frac{7}{22}$

**E**  $\frac{5}{2}$

**F**  $\frac{7}{2}$

88 A pendulum bob of mass 10 g is suspended by a light, inextensible string of length 50 cm.

The bob is released from rest at position X.

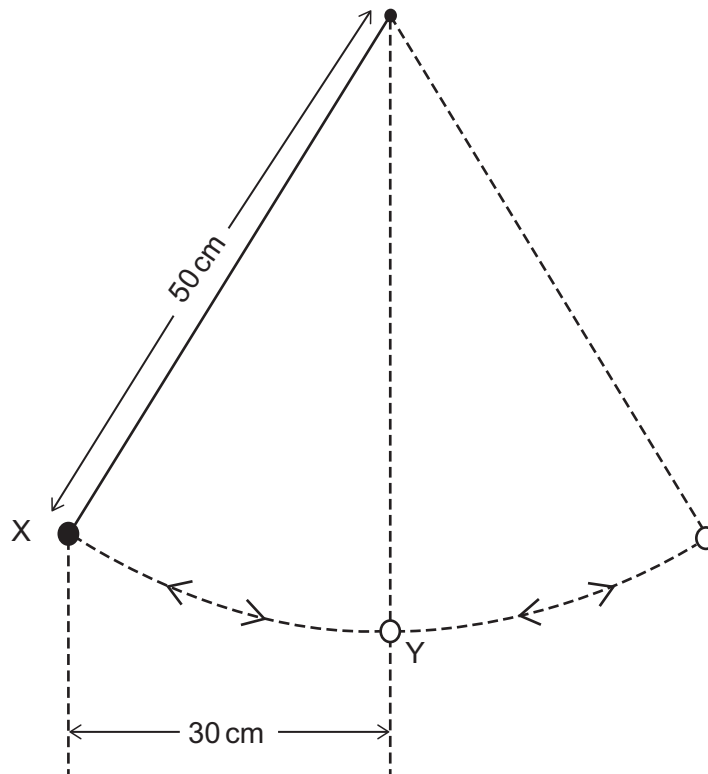

What is the speed of the bob as it passes through position Y?

(gravitational field strength  $g = 10 \text{ N kg}^{-1}$ ; assume that resistive forces are negligible)

- A  $\sqrt{2} \text{ ms}^{-1}$
- B  $\sqrt{4} \text{ ms}^{-1}$
- C  $\sqrt{6} \text{ ms}^{-1}$
- D  $\sqrt{8} \text{ ms}^{-1}$
- E  $\sqrt{10} \text{ ms}^{-1}$

- 89** The dimensions of a solid cuboid, in cm, are  $x$ ,  $2x$  and  $y$

The volume of the cuboid is  $576 \text{ cm}^3$ .

At this volume, the surface area of the cuboid has its maximum value.

What is the area, in  $\text{cm}^2$ , of the face that has the largest area?

**A**  $2(288)^{\frac{2}{3}}$

**B** 72

**C** 96

**D** 432

**E**  $4(144)^{\frac{2}{3}}$

- 90** An object is thrown vertically upwards from ground level with an initial velocity of  $40 \text{ m s}^{-1}$ .

2.0 seconds later another object is released from a height above the ground and falls vertically from rest.

Both of the objects hit the ground at the same time.

From what height above the ground was the second object released?

(gravitational field strength  $g = 10 \text{ N kg}^{-1}$ ; air resistance can be ignored)

**A** 80 m

**B** 180 m

**C** 320 m

**D** 500 m

**E** 900 m

**BLANK PAGE**





**Natural Sciences Admissions Assessment – Section 1 2018 D568/11**

Candidate number

N

Centre number

Date of birth (DD MM YYYY)

First name(s)

Surname / Family name

Fill in the appropriate circle for your chosen answer e.g.

A B C D E  
○ ● ○ ○ ○

Use a soft pencil. If you make a mistake, erase thoroughly and try again.

\* 5 8 9 0 3 7 3 7 9 1 \*

**ALL** candidates must complete Part A

**Part A: Mathematics**

- |   |                                    |    |                                    |
|---|------------------------------------|----|------------------------------------|
| 1 | A B C D E F G<br>○ ○ ○ ○ ○ ○ ○ ○   | 10 | A B C D E<br>○ ○ ○ ○ ○             |
| 2 | A B C D E F<br>○ ○ ○ ○ ○ ○         | 11 | A B C D E<br>○ ○ ○ ○ ○             |
| 3 | A B C D E F G H<br>○ ○ ○ ○ ○ ○ ○ ○ | 12 | A B C D E F G H<br>○ ○ ○ ○ ○ ○ ○ ○ |
| 4 | A B C D E F G H<br>○ ○ ○ ○ ○ ○ ○ ○ | 13 | A B C D E F G<br>○ ○ ○ ○ ○ ○ ○     |
| 5 | A B C D E F<br>○ ○ ○ ○ ○ ○         | 14 | A B C D E<br>○ ○ ○ ○ ○             |
| 6 | A B C D E F<br>○ ○ ○ ○ ○ ○         | 15 | A B C D E F G H<br>○ ○ ○ ○ ○ ○ ○ ○ |
| 7 | A B C D E F<br>○ ○ ○ ○ ○ ○         | 16 | A B C D E F<br>○ ○ ○ ○ ○ ○         |
| 8 | A B C D E F<br>○ ○ ○ ○ ○ ○         | 17 | A B C D E F G H<br>○ ○ ○ ○ ○ ○ ○ ○ |
| 9 | A B C D E F G H<br>○ ○ ○ ○ ○ ○ ○ ○ | 18 | A B C D E F<br>○ ○ ○ ○ ○ ○         |



# N

Candidate number

N					
---	--	--	--	--	--

 Attempt any **TWO** of parts B, C, D, E.

**Part B: Physics**

- |    |                                    |    |                                    |
|----|------------------------------------|----|------------------------------------|
| 19 | A B C D E F G H<br>○ ○ ○ ○ ○ ○ ○ ○ | 28 | A B C D E F G H<br>○ ○ ○ ○ ○ ○ ○ ○ |
| 20 | A B C D E F G<br>○ ○ ○ ○ ○ ○ ○ ○   | 29 | A B C D E F<br>○ ○ ○ ○ ○ ○ ○ ○     |
| 21 | A B C D E F G H<br>○ ○ ○ ○ ○ ○ ○ ○ | 30 | A B C D E<br>○ ○ ○ ○ ○ ○ ○ ○       |
| 22 | A B C D E F G<br>○ ○ ○ ○ ○ ○ ○ ○   | 31 | A B C D E<br>○ ○ ○ ○ ○ ○ ○ ○       |
| 23 | A B C D E F<br>○ ○ ○ ○ ○ ○ ○ ○     | 32 | A B C D E F<br>○ ○ ○ ○ ○ ○ ○ ○     |
| 24 | A B C D E F G H<br>○ ○ ○ ○ ○ ○ ○ ○ | 33 | A B C D E F G H<br>○ ○ ○ ○ ○ ○ ○ ○ |
| 25 | A B C D E<br>○ ○ ○ ○ ○ ○ ○ ○       | 34 | A B C D E F G<br>○ ○ ○ ○ ○ ○ ○ ○   |
| 26 | A B C D E<br>○ ○ ○ ○ ○ ○ ○ ○       | 35 | A B C D E F<br>○ ○ ○ ○ ○ ○ ○ ○     |
| 27 | A B C D E F G H<br>○ ○ ○ ○ ○ ○ ○ ○ | 36 | A B C D E F G H<br>○ ○ ○ ○ ○ ○ ○ ○ |

**Part C: Chemistry**

- |    |                                    |    |                                    |
|----|------------------------------------|----|------------------------------------|
| 37 | A B C D E F<br>○ ○ ○ ○ ○ ○ ○ ○     | 46 | A B C D E F G H<br>○ ○ ○ ○ ○ ○ ○ ○ |
| 38 | A B C D E<br>○ ○ ○ ○ ○ ○ ○ ○       | 47 | A B C D E F<br>○ ○ ○ ○ ○ ○ ○ ○     |
| 39 | A B C D E<br>○ ○ ○ ○ ○ ○ ○ ○       | 48 | A B C D E F G H<br>○ ○ ○ ○ ○ ○ ○ ○ |
| 40 | A B C D E F<br>○ ○ ○ ○ ○ ○ ○ ○     | 49 | A B C D E<br>○ ○ ○ ○ ○ ○ ○ ○       |
| 41 | A B C D E F<br>○ ○ ○ ○ ○ ○ ○ ○     | 50 | A B C D E F<br>○ ○ ○ ○ ○ ○ ○ ○     |
| 42 | A B C D E F<br>○ ○ ○ ○ ○ ○ ○ ○     | 51 | A B C D E F G<br>○ ○ ○ ○ ○ ○ ○ ○   |
| 43 | A B C D E F G H<br>○ ○ ○ ○ ○ ○ ○ ○ | 52 | A B C D E F<br>○ ○ ○ ○ ○ ○ ○ ○     |
| 44 | A B C D E<br>○ ○ ○ ○ ○ ○ ○ ○       | 53 | A B C D E F G<br>○ ○ ○ ○ ○ ○ ○ ○   |
| 45 | A B C D E F<br>○ ○ ○ ○ ○ ○ ○ ○     | 54 | A B C D E F G<br>○ ○ ○ ○ ○ ○ ○ ○   |

**Part D: Biology**

- |    |                                    |    |                                    |
|----|------------------------------------|----|------------------------------------|
| 55 | A B C D E F G H<br>○ ○ ○ ○ ○ ○ ○ ○ | 64 | A B C D E F G H<br>○ ○ ○ ○ ○ ○ ○ ○ |
| 56 | A B C D E F G H<br>○ ○ ○ ○ ○ ○ ○ ○ | 65 | A B C D E F G H<br>○ ○ ○ ○ ○ ○ ○ ○ |
| 57 | A B C D E F G H<br>○ ○ ○ ○ ○ ○ ○ ○ | 66 | A B C D E<br>○ ○ ○ ○ ○ ○ ○ ○       |
| 58 | A B C D E F G H<br>○ ○ ○ ○ ○ ○ ○ ○ | 67 | A B C D E F G H<br>○ ○ ○ ○ ○ ○ ○ ○ |
| 59 | A B C D E F G<br>○ ○ ○ ○ ○ ○ ○ ○   | 68 | A B C D E F G<br>○ ○ ○ ○ ○ ○ ○ ○   |
| 60 | A B C D E F<br>○ ○ ○ ○ ○ ○ ○ ○     | 69 | A B C D E F G H<br>○ ○ ○ ○ ○ ○ ○ ○ |
| 61 | A B C D E F G H<br>○ ○ ○ ○ ○ ○ ○ ○ | 70 | A B C D E F G H<br>○ ○ ○ ○ ○ ○ ○ ○ |
| 62 | A B C D E F G H<br>○ ○ ○ ○ ○ ○ ○ ○ | 71 | A B C D E F G H<br>○ ○ ○ ○ ○ ○ ○ ○ |
| 63 | A B C D E F<br>○ ○ ○ ○ ○ ○ ○ ○     | 72 | A B C D E F G H<br>○ ○ ○ ○ ○ ○ ○ ○ |

**Part E: Advanced Maths & Physics**

- |    |                                    |    |                                  |
|----|------------------------------------|----|----------------------------------|
| 73 | A B C D E<br>○ ○ ○ ○ ○ ○ ○ ○       | 82 | A B C D E<br>○ ○ ○ ○ ○ ○ ○ ○     |
| 74 | A B C D E F G H<br>○ ○ ○ ○ ○ ○ ○ ○ | 83 | A B C D E<br>○ ○ ○ ○ ○ ○ ○ ○     |
| 75 | A B C D E F<br>○ ○ ○ ○ ○ ○ ○ ○     | 84 | A B C D E F<br>○ ○ ○ ○ ○ ○ ○ ○   |
| 76 | A B C D E F<br>○ ○ ○ ○ ○ ○ ○ ○     | 85 | A B C D E F G<br>○ ○ ○ ○ ○ ○ ○ ○ |
| 77 | A B C D E F G H<br>○ ○ ○ ○ ○ ○ ○ ○ | 86 | A B C D E F G<br>○ ○ ○ ○ ○ ○ ○ ○ |
| 78 | A B C D E<br>○ ○ ○ ○ ○ ○ ○ ○       | 87 | A B C D E F<br>○ ○ ○ ○ ○ ○ ○ ○   |
| 79 | A B C D E F<br>○ ○ ○ ○ ○ ○ ○ ○     | 88 | A B C D E<br>○ ○ ○ ○ ○ ○ ○ ○     |
| 80 | A B C D E F G<br>○ ○ ○ ○ ○ ○ ○ ○   | 89 | A B C D E<br>○ ○ ○ ○ ○ ○ ○ ○     |
| 81 | A B C D E F<br>○ ○ ○ ○ ○ ○ ○ ○     | 90 | A B C D E<br>○ ○ ○ ○ ○ ○ ○ ○     |



# Natural Sciences Admissions Assessment – Past paper 2018

## Section 1

### Answer key

Question	Answer key
1	E
2	B
3	H
4	D
5	C
6	E
7	A
8	C
9	E
10	D
11	C
12	F
13	E
14	A
15	C
16	C
17	G
18	B
19	B
20	B
21	G
22	E
23	E
24	C
25	C
26	A
27	A
28	C
29	E
30	C
31	B
32	E
33	H
34	C
35	E
36	A
37	C
38	C
39	A
40	D
41	B
42	E
43	F
44	A
45	E

Question	Answer key
46	C
47	A
48	D
49	B
50	A
51	C
52	C
53	B
54	E
55	F
56	D
57	E
58	E
59	E
60	E
61	H
62	G
63	A
64	B
65	F
66	E
67	A
68	C
69	H
70	G
71	F
72	B
73	A
74	E
75	D
76	F
77	C
78	D
79	E
80	F
81	C
82	D
83	C
84	F
85	D
86	A
87	E
88	A
89	C
90	B



**NATURAL SCIENCES  
ADMISSIONS ASSESSMENT**

**D568/12**

**Wednesday 31 October 2018**

**40 minutes**

**SECTION 2**

\* 4 1 0 3 3 3 1 1 9 0 \*

Candidate number	N						Centre number						
------------------	---	--	--	--	--	--	---------------	--	--	--	--	--	--

	d	d			m	m			y	y	y	y
Date of birth			-			-						

First name(s)	
---------------	--

Surname / Family name	
-----------------------	--

**INSTRUCTIONS TO CANDIDATES**

**Please read these instructions carefully, but do not open the question paper until you are told that you may do so.** This paper is Section 2 of 2.

There are six questions in this paper, of which you should answer any **two**.

There are 20 marks for each question. In total 40 marks are available.

You should write your answers in the spaces provided in this question paper. Please complete this section in **black pen**. Pencil may be used for graphs and diagrams only.

You can use the blank pages inside this booklet for rough working or notes, but **no extra paper** is allowed. Only answers in the spaces indicated in the paper will be marked.

Calculators may be used in this section. Please record your calculator model in the box below:

Calculator model	
------------------	--

Write the numbers of the questions you answer in the order attempted in the boxes below:

Question number

**Please wait to be told you may begin before turning this page.**

This question paper consists of 28 printed pages and 4 blank pages.

PV5

**This page is intentionally left blank for your rough working or notes.**

Physics

Question P1

A ball of mass  $m$  is dropped and falls vertically from a high window. The graph illustrates the height of the ball above the ground,  $h$ , as a function of time  $t$  since the ball was dropped.

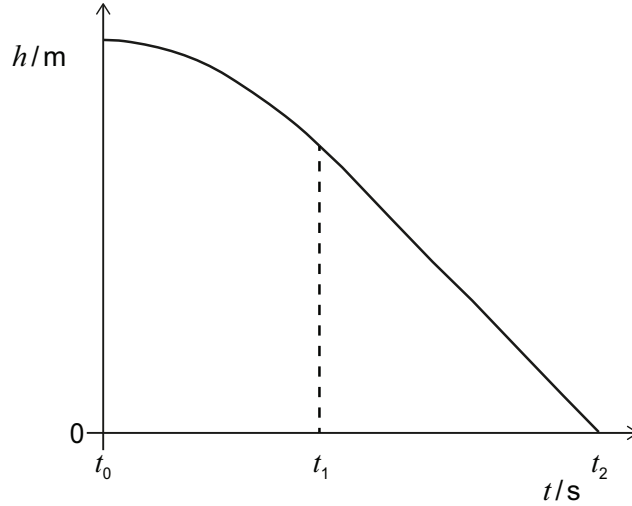

a) In words, relate the speed of the ball to the gradient of the graph at time  $t_0$ , and in the two time intervals  $t_0$  to  $t_1$ ,  $t_1$  to  $t_2$ .

[6 marks]

Answer: .....

.....

.....

.....

.....

.....

.....

.....

.....

.....

.....

.....

.....

.....

.....

.....

.....

.....

.....

.....

.....

.....

.....

.....

b) The drag force on the ball caused by air resistance is given by  $F_d$ .

Using Newton's second law, find an equation for the acceleration  $a$  of the ball in terms of  $F_d$ ,  $m$ , and  $g$ , where  $g$  is the gravitational field strength.

[2 marks]

Answer: .....

.....

.....

.....

.....

.....

c) The drag force on the ball is given by  $F_d = \frac{1}{4}\pi\rho r^2 v^2$ , where  $\rho$  is the density of the air,  $r$  is the radius of the ball, and  $v$  is the instantaneous speed of the ball.

Find an expression for the terminal speed of the ball  $v_t$  in terms of  $m$ ,  $g$ ,  $r$  and  $\rho$ .

[3 marks]

Answer: .....

.....

.....

.....

.....

.....

.....

.....

.....

d) Calculate the value of the terminal speed of the ball given that it has a mass  $m = 25\text{ g}$ , a radius  $r = 25\text{ cm}$ , and that the density of the air  $\rho = 1.2\text{ kg m}^{-3}$ .

(gravitational field strength =  $9.8\text{ N kg}^{-1}$ )

[2 marks]

Answer: .....

.....

.....

.....

.....

.....

e) Sketch a graph of the ball's speed against time, labelling the terminal speed of the ball.

In words, relate the acceleration of the ball to the gradient of your speed–time graph.

[4 marks]

Answer:

.....

.....

.....

.....

.....

.....





**Question P2**

Assume throughout this question that the cells and batteries have no internal resistance.

A light-emitting diode (LED) has the ideal  $I$ - $V$  characteristic graph shown in Fig. 2a:

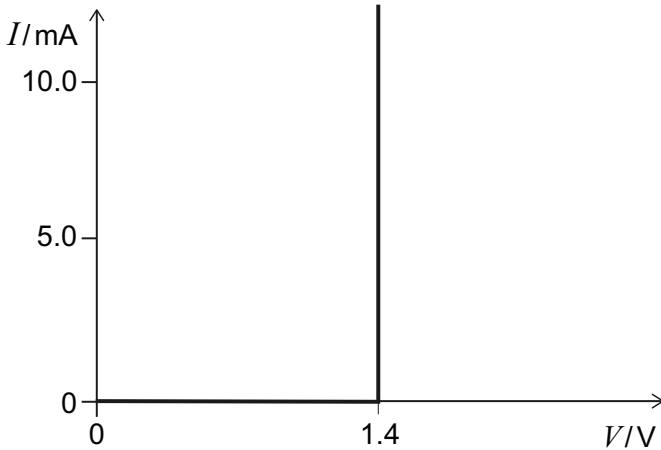

**Figure 2a**

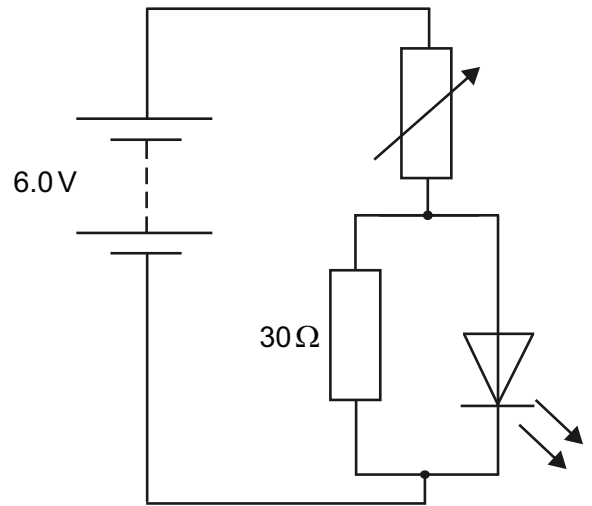

**Figure 2b**

If the potential difference across the LED is less than 1.4 V, no current passes through it. When a current does pass through the LED, the potential difference across it is always 1.4 V.

This LED is connected into the circuit shown in Fig. 2b, and the variable resistor is adjusted until there is a current of 8.0 mA through the LED. The battery has an emf of 6.0 V.

- a) (i)** What is the potential difference across the  $30\ \Omega$  resistor? **[1 mark]**

Answer: .....

.....

.....

- (ii)** What is the current through the  $30\ \Omega$  resistor? **[1 mark]**

Answer: .....

.....

.....

**b) (i)** What is the current through the variable resistor? **[1 mark]**

Answer: .....  
.....  
.....

**(ii)** What is the potential difference across the variable resistor? **[1 mark]**

Answer: .....  
.....  
.....

**(iii)** What is the resistance of the variable resistor? **[1 mark]**

Answer: .....  
.....  
.....

- c) The following circuit is constructed with a battery of emf 6.0 V, two fixed resistors, one variable resistor, and a voltmeter, as shown in Fig. 2c.

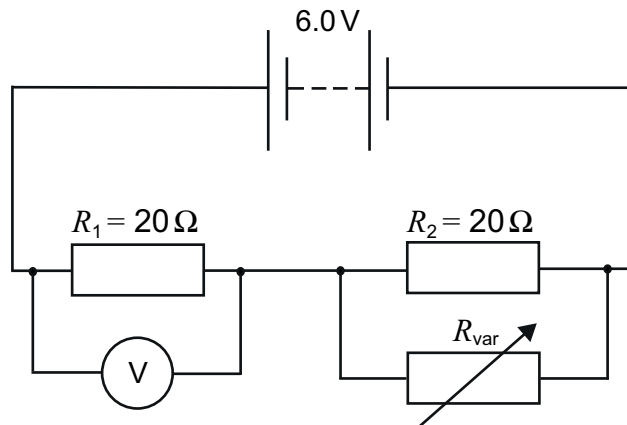

Figure 2c

$R_1 = R_2 = 20\ \Omega$ , and  $R_{var}$  can be varied between 0 and  $80\ \Omega$ .

- (i) When  $R_{var}$  is set to  $20\ \Omega$ , what is the voltage shown on the voltmeter?

[1 mark]

Answer: .....

.....

.....

- (ii) Sketch a graph of the voltage shown on the voltmeter against  $R_{var}$  for values of  $R_{var}$  between 0 and  $80\ \Omega$ . Plot your result from part (i) on your graph.

[3 marks]

Answer:

- (iii) Calculate the potential difference across the variable resistor, and the power dissipated in the variable resistor, for  $R_{\text{var}} = 0.0 \Omega, 5.0 \Omega, 20 \Omega, 50 \Omega$  and  $80 \Omega$ .

[5 marks]

Answer:

$R_{\text{var}} / \Omega$	
0.0	
5.0	
20	
50	
80	

- (iv) Using your results from part (iii), sketch a labelled graph of the power dissipated in the variable resistor against  $R_{\text{var}}$  from 0 to  $80\ \Omega$ .

**[3 marks]**

Answer:

- d) A potentiometer is a three-terminal device often used as a variable resistor by using only two of the three terminals (one end of the resistive track and the sliding contact). An example is shown schematically in Fig. 2d. In a logarithmic potentiometer the resistance varies with the angle of rotation,  $\theta$ .

The graph in Fig. 2e shows how the logarithm of the resistance  $R_{AB}$  varies linearly with angle  $\theta$ .

$\theta$  can vary between  $0^\circ$  and  $270^\circ$ .

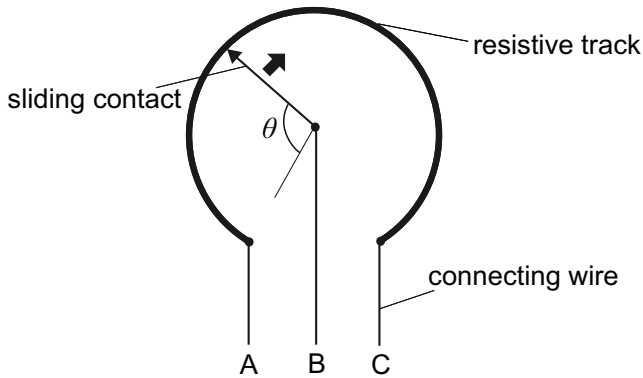

Figure 2d

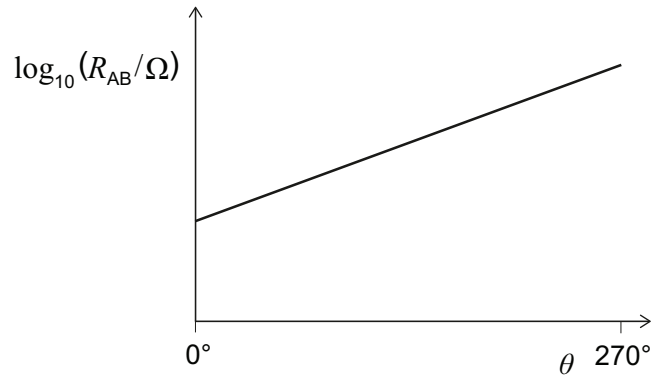

Figure 2e

If the resistance when  $\theta = 0^\circ$  is  $R_{AB} = 1.00 \text{ k}\Omega$ , and when  $\theta = 270^\circ$  is  $R_{AB} = 2.00 \text{ M}\Omega$ , what is the value of  $R_{AB}$  when  $\theta = 110^\circ$ ?

[3 marks]

Answer: .....

.....

.....

.....

.....

.....

.....

.....

.....

.....

**This page is intentionally left blank for your rough working or notes.**



<b>H</b>	<b>He</b>
1 1.008	2 4.003
<b>Li</b>	<b>Be</b>
3 6.941	4 9.012
<b>Na</b>	<b>Mg</b>
11 22.99	12 24.31
<b>K</b>	<b>Ca</b>
19 39.10	20 40.08
<b>Rb</b>	<b>Sr</b>
37 85.47	38 87.62
<b>Cs</b>	<b>Ba</b>
55 132.9	56 137.3
<b>Fr</b>	<b>Ra</b>
87	88
	<b>Ac<sup>†</sup></b>
	89

<b>symbol</b>
<b>atomic number</b>
<b>relative atomic mass (<i>A<sub>r</sub></i>)</b>

<b>B</b>	<b>C</b>	<b>N</b>	<b>O</b>	<b>F</b>	<b>Ne</b>
5 10.81	6 12.01	7 14.01	8 16.00	9 19.00	10 20.18
<b>Al</b>	<b>Si</b>	<b>P</b>	<b>S</b>	<b>Cl</b>	<b>Ar</b>
13 26.98	14 28.09	15 30.97	16 32.06	17 35.45	18 39.95
<b>Ga</b>	<b>Ge</b>	<b>As</b>	<b>Se</b>	<b>Br</b>	<b>Kr</b>
31 69.72	32 72.63	33 74.92	34 78.97	35 79.90	36 83.80
<b>In</b>	<b>Sn</b>	<b>Sb</b>	<b>Te</b>	<b>I</b>	<b>Xe</b>
49 114.8	50 118.7	51 121.8	52 127.6	53 126.9	54 131.3
<b>Tl</b>	<b>Pb</b>	<b>Bi</b>	<b>Po</b>	<b>At</b>	<b>Rn</b>
81 204.4	82 207.2	83 209.0	84	85	86

	<b>Zn</b>	<b>Cu</b>	<b>Ni</b>	<b>Co</b>	<b>Fe</b>	<b>Mn</b>	<b>Cr</b>	<b>V</b>	<b>Ti</b>	<b>Sc</b>	<b>Y</b>	<b>Zr</b>	<b>Nb</b>	<b>Ta</b>	<b>Hf</b>	<b>La*</b>	<b>Ba</b>	<b>Ra</b>	
	30 65.38	29 63.55	28 58.69	27 58.93	26 55.85	25 54.94	24 52.00	23 50.94	22 47.87	21 44.96	39 88.91	40 91.22	41 92.91	72 178.5	73 180.9	74 183.8	75 186.2	76 190.2	77 192.2
	<b>Cd</b>	<b>Ag</b>	<b>Pd</b>	<b>Rh</b>	<b>Ru</b>	<b>Tc</b>	<b>Mo</b>	<b>Nb</b>	<b>Zr</b>	<b>Y</b>	<b>Zr</b>	<b>Nb</b>	<b>Ta</b>	<b>Hf</b>	<b>La*</b>	<b>Ba</b>	<b>Ra</b>	<b>Ac<sup>†</sup></b>	
	48 112.4	47 107.9	46 106.4	45 102.9	44 101.1	43 95.95	42 95.95	41 92.91	40 91.22	39 88.91	89	90	91	92	93	94	95	96	97
	<b>Hg</b>	<b>Au</b>	<b>Pt</b>	<b>Ir</b>	<b>Os</b>	<b>Re</b>	<b>W</b>	<b>Ta</b>	<b>Hf</b>	<b>La*</b>	<b>Ba</b>	<b>Ra</b>	<b>Ac<sup>†</sup></b>	<b>Pb</b>	<b>Bi</b>	<b>Po</b>	<b>At</b>	<b>Rn</b>	
	80 200.6	79 197.0	78 195.1	77 192.2	76 190.2	75 186.2	74 183.8	73 180.9	72 178.5	89	90	91	92	82 207.2	83 209.0	84	85	86	

<b>*Lanthanides</b>	<b>Ce</b>	<b>Pr</b>	<b>Nd</b>	<b>Pm</b>	<b>Sm</b>	<b>Eu</b>	<b>Gd</b>	<b>Tb</b>	<b>Dy</b>	<b>Ho</b>	<b>Er</b>	<b>Tm</b>	<b>Yb</b>	<b>Lu</b>
	58 140.1	59 140.9	60 144.2	61	62 150.4	63 152.0	64 157.3	65 158.9	66 162.5	67 164.9	68 167.3	69 168.9	70 173.0	71 175.0
<b>†Actinides</b>	<b>Th</b>	<b>Pa</b>	<b>U</b>	<b>Np</b>	<b>Pu</b>	<b>Am</b>	<b>Cm</b>	<b>Bk</b>	<b>Cf</b>	<b>Es</b>	<b>Fm</b>	<b>Md</b>	<b>No</b>	<b>Lr</b>
	90 232.0	91 231.0	92 238.0	93	94	95	96	97	98	99	100	101	102	103

## Chemistry

### Question C1

- a) Ketones react with hydroxylamine,  $\text{NH}_2\text{OH}$ , to give oximes. An example of such a reaction involving the ketone propanone is shown below:

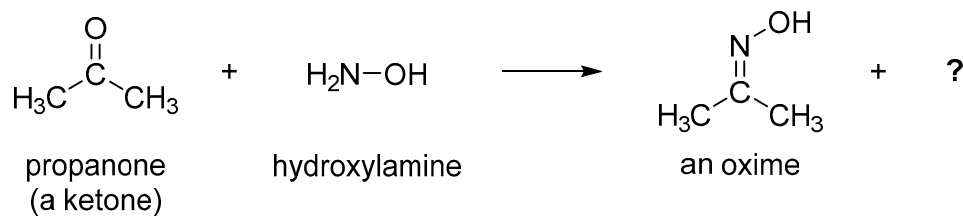

- (i) In addition to the oxime, this reaction produces a second product. Suggest what this molecule might be.

[1 mark]

Answer: .....

.....

- (ii) Draw the structure of the oxime that you would expect to be formed from the reaction of the ketone cyclohexanone with hydroxylamine.

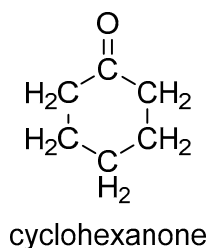

[2 marks]

Answer:

- (iii) Oximes are weakly acidic. For the oxime below, explain which hydrogen atom will be the most acidic and draw the structure of the resulting anion  $X^-$ .

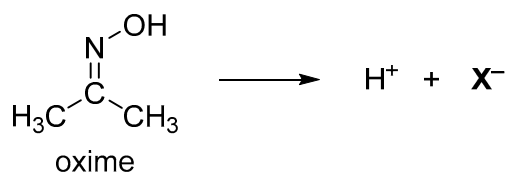

[3 marks]

Answer: .....

.....

.....

.....

- b) Under acidic conditions, oximes undergo the following rearrangement reaction (note carefully that there are two different groups R and R').

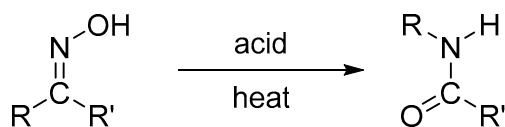

Give the analogous structures into which each of the following oximes rearrange under the same conditions.

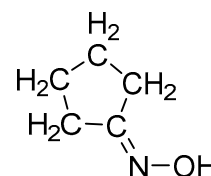
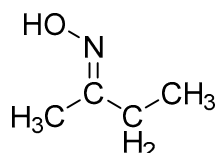
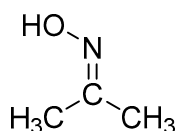

[4 marks]

Answer:

- c) Dimethylglyoxime reacts with  $\text{Ni}^{2+}$  ions in aqueous solution under mildly basic conditions to give a complex which is an insoluble red precipitate. The reaction involves two molecules of dimethylglyoxime and also results in the production of two  $\text{H}^+$  ions.

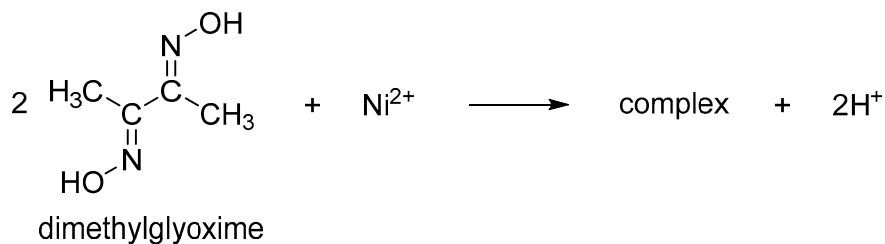

Assuming that the above equation is balanced, determine the **molecular formula** of the complex and its relative molecular mass; a structural formula is **not** required.

(Relative atomic mass data is given in the Periodic Table on page 14.)

**[4 marks]**

Answer: .....

.....

.....

.....

.....

.....

.....

.....

.....

.....

- d) The reaction between dimethylglyoxime and  $\text{Ni}^{2+}$  ions can be used to determine the nickel content of alloys by weighing the amount of the red precipitate produced from a known mass of a sample of an alloy.

A sample of mass 1.50 g of an alloy was dissolved in dilute acid and an excess of dimethylglyoxime was then added to the resulting solution. The pH was then adjusted to make the solution mildly alkaline, and this resulted in the formation of a red precipitate. The precipitate was carefully filtered off, dried and then weighed. The mass of the dry precipitate was 0.368 g.

Determine the nickel content of the alloy, expressed as a percentage by mass.

**[4 marks]**

Answer: .....

.....

.....

.....

.....

.....

.....

.....

.....

.....

.....

.....

.....

.....

.....

.....

- e) Other metal ions, such as  $\text{Pd}^{2+}$  or  $\text{Pt}^{2+}$ , also react with dimethylglyoxime to give insoluble precipitates. What effect would the presence of palladium in the alloy have on the value of the nickel content determined using the method in part d) ?

**[2 marks]**

Answer: .....

.....

.....

.....

.....

**Question C2**

- a) Write a balanced chemical equation for the reaction between  $\text{CO}_2(\text{g})$  and  $\text{OH}^-(\text{aq})$ , giving  $\text{CO}_3^{2-}(\text{aq})$  as one of the products.

**[1 mark]**

Answer: .....

.....

.....

- b) An organic molecule is known to contain C, H and O only. A sample of mass 0.100 g is carefully burnt in the presence of excess oxygen. The resulting gases are passed over a desiccant (drying agent), and it is observed that the mass of the desiccant increases by 0.0931 g.

After passing through the desiccant the gases are bubbled through  $25.0 \text{ cm}^3$  of a solution of  $1.00 \text{ mol dm}^{-3}$  NaOH. The solution is then titrated against  $1.00 \text{ mol dm}^{-3}$  HCl, and the end point is found to be when  $14.7 \text{ cm}^3$  of the acid has been added.

- (i) Calculate the amount in moles of  $\text{H}_2\text{O}$  produced by the combustion.

**[2 marks]**

Answer: .....

.....

.....

.....

- (ii) Calculate the amount in moles of  $\text{CO}_2$  absorbed by the NaOH solution.

**[4 marks]**

Answer: .....

.....

.....

.....

.....

.....

.....

.....



d) Write a balanced chemical equation in which  $\text{Fe}^{2+}$  is oxidised to  $\text{Fe}^{3+}$  by  $\text{MnO}_4^-$  in an **acidic aqueous solution** and in which the Mn is reduced to a species with oxidation state +2. Your equation must balance for both atoms and charge, and you may **not** use free electrons ( $e^-$ ) to achieve this.

[4 marks]

Answer: .....

.....

.....

.....

.....

.....

.....

.....

.....

.....

.....



**This page is intentionally left blank for your rough working or notes.**

## Biology

### Question B1

- a) Sketch a simple diagram of a eukaryotic cell, and label the locations where DNA transcription and RNA translation take place.

**[2 marks]**

Answer:

- b) When RNA is translated into protein, it is read in triplets (codons).

What proportion of codons might be viewed as redundant in the genetic code (i.e. in excess of the minimum needed to code for all amino acids)?

**[2 marks]**

Answer: .....

.....

.....

.....

.....

.....

c) What is an advantage of having more codons in the genetic code than there are amino acids? **[2 marks]**

Answer: .....

.....

.....

.....

.....

.....

d) A ribosome can translate 18 bases per second.

How many seconds would it take to produce a protein that was 299 amino acids long? **[2 marks]**

Answer: .....

.....

.....

.....

.....

.....

e) Imagine that an alien organism is found that translates its RNA using pairs of nucleotides instead of triplets.

During translation, the alien organism can use 50 possible amino acids (rather than the 20 found in humans).

What is the minimum number of different types of nucleotides that would be needed to code for all of the possible amino acids? **[2 marks]**

Answer: .....

.....

.....

.....

.....

.....





**Question B2**

The diagram below shows eight  $2\text{ m} \times 2\text{ m}$  quadrats that have been placed into a  $14\text{ m} \times 10\text{ m}$  field that has recently been colonised by a small invasive plant (each plant is shown by a flower symbol).

[diagram not to scale]

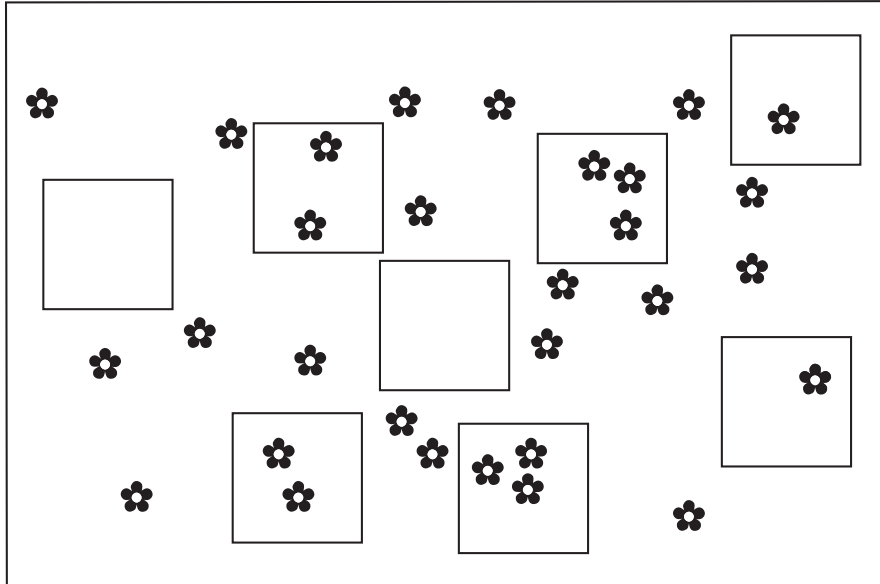

a) Describe one benefit **and** one problem associated with using quadrats in a study like this.

[2 marks]

Answer: .....

.....

.....

.....

.....

.....

b) Calculate the frequency of occurrence of the species in the quadrats.

[1 mark]

Answer: .....

.....

.....

c) Calculate the mean number of plants found per square metre in the quadrats.

**[2 marks]**

Answer: .....

.....

.....

.....

.....

.....

d) For the field as a whole, this population grows by 70 individuals per week.

How long will the population take to reach an average density of two plants per square metre in the 14 m × 10 m field?

**[2 marks]**

Answer: .....

.....

.....

.....

.....

.....

e) The invasive plant only produces flowers once every 5 years.

Explain why the plant produces flowers, and why flowers might be produced on this timescale.

**[3 marks]**

Answer: .....

.....

.....

.....

.....

.....

.....

.....

.....

.....







**This page is intentionally left blank for your rough working or notes.**

**N**

## Physics: Examiners comments for consideration in admissions decisions

### Recommendations for during the decision making process:

1. Reviewing the actual section 2 scripts of the candidates will provide useful information to add to the decision process – in particular when considering the mathematical fluency and accuracy in combination with the ability to explain and understand the underlying physical principles (see question P1 comments)

The last three years have clearly shown that candidates do not use their time evenly, with the first question that they attempt dominating the mark profile. When considering the moderation spreadsheet alone, it is not apparent which was the first question; furthermore each question has a different mean, making these marks not as useful as they could be.

2. It would be my recommendation to Directors of Studies, therefore, that marks for each question are scaled to match the means, and the total score across both questions is then considered. (e.g. P1+C1, P1+C2). Given the means this year, this wouldn't need to be a laborious process. For example, if we wished the mean for all subjects to be 10 then a simple scaling (calculated in the spreadsheet) using something like  $10 + \left( \frac{N \leq score}{N_{total}} - 0.5 \right) * 20$  [which scales the top mark to be  $20 \left( \frac{N \leq 20}{N_{total}} = 1 \right)$ ] would enable marks to be added and the total across both questions considered.

### Question P1

*This question was designed not only to test students' mathematical ability, fluency and accuracy but also to test their understanding of physical concepts and their ability to explain them. This was a useful exercise as it was clear that many students (often overseas students) were able to reliably and efficiently perform calculations, but had no physical understanding of what this meant, and were therefore unable to describe or draw the graphs in part (a) and (e). It was clear from this question that students lacked practice in explaining physical systems in a concise manner with simple short statements. They often wrote complicated, confused and contradictory statements.*

*From the last three years of marking the admissions tests, it is clear that the first question on the paper is attempted by the greatest number of students and, generally, students were able to make good progress on this question. Our decisions about marks were therefore quite strict (to discriminate between candidates who had a clear and accurate understanding of the physics and were reliable and critical with their mathematics) and taken within the whole context of all of the scripts.*

*Most students progressed all the way through this question – possibly to the detriment of later questions.*

### Question P2

*The question on simple circuits was designed to be accessible to most A level students who have studied electric circuits. Only two equations are required;  $V = IR$  and  $P = \frac{V^2}{R}$ . The parts of this question were separate, requiring simple calculations or sometimes the graphs could be sketched without numerical calculations. Even within the sections the parts of the question could be approached without having correctly obtained the earlier answers in the section.*

*Somewhat evident was the lack of practice in doing simple calculations without forgetting the component they were meant to be considering halfway through. So a student would find some set of potentials across the "other" resistor in the circuit. This well-meaning effort on their part could be very frustrating when you could see that they could have answered the question correctly.*

*Generally, they found the electricity question hard (although it is certainly a very straightforward question of its type) but they tend not to have a feel for the behaviour of currents and potentials in simple circuits. They can do calculations, but may get confused along the way by having to consider more than one step at a time in their head. They could set the steps down, but they are not used to multistep calculations without a support step in the middle. These were like physics problems, without the level of technical difficulty, but with the requirement to hold on to more than one thought at a time.*

*There were a small number of students from overseas who appeared to know almost no electricity. Other than that, students who attempted the question could generally make progress, getting sections correct or incorrect independently, even though one might think that they had the principle at one moment whilst they then appeared to lose their way in another section.*

*When calculating a table of results, it was sometimes evident that they were using a calculator, but were not systematic about tabulating the intermediate results and seeing that they followed a pattern.*

*It was quite clear that they did not have enough time to complete the question, particularly if they chose to do the two physics questions and naturally had spent too long on the first one.*

*The mark scheme had some amendments made as a result of seeing a sample of student scripts, but some of these adjusted details for awarding marks have not been included here.*

## Physics

### Question P1

A ball, of mass  $m$  is dropped and falls vertically from a high window. The graph illustrates the height of the ball above the ground,  $h$ , as a function of time  $t$  since the ball was dropped.

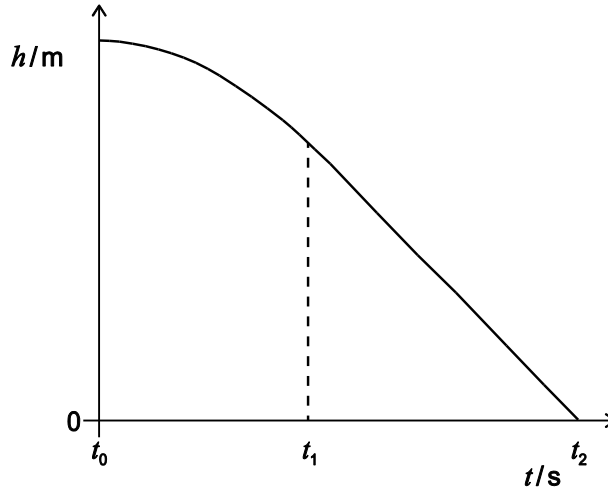

- a) In words, relate the speed of the ball to the gradient of the graph at time  $t_0$  and in the two time intervals  $t_0$  to  $t_1$ ,  $t_1$  and  $t_2$ .

[6 marks]

Answer: *Students who performed poorly on this part of the question usually did so because they didn't actually answer the question asked. A few talked about forces on the ball correctly but without relating the speed of the ball to the gradient of the graph. Some students spent much longer than necessary writing correct physical statements but those statements were not relevant to the question. Where incorrect physics was cited, marks were not given (e.g. accelerating at an increasing rate). It was clear from this question that students lacked practice in explaining physical systems in a concise manner with simple short statements. They often wrote complicated, confused and contradictory statements.*

**At  $t_0$**  : the speed of the ball is zero at the start [1 mark]

therefore the gradient of the line is zero (flat) [1 mark]

*Many students neglected to answer this part of the question.*

**$t_0$  to  $t_1$** : the ball is accelerating [1 mark]

.....therefore the gradient is always changing [1 mark]

*(or the line is curved, or the gradient is not constant)*

The gradient of  $h-t$  tells us about the velocity and the gradient is always increasing which means the velocity is always increasing therefore the ball is accelerating due to a resultant force.

*Students who said (or inferred) that acceleration was constant (some said at  $g$ ) between  $t_0$  and  $t_1$  were not given the first mark.*

**$t_1$  to  $t_2$** : the ball has reached terminal (or maximum) speed [1 mark]

therefore the gradient is constant because there is no resultant force on the ball. *(or the line is straight will be accepted)* [1 mark]

*This part was usually done well.*

b) The drag force on the ball caused by air resistance is given by  $F_d$ .

Using Newton's second law, find an equation for the acceleration  $a$  of the ball in terms of  $F_d$ ,  $m$ , and  $g$  where  $g$  is the gravitational field strength.

[2 marks]

Answer: ...Using Newton's Second Law

$$mg - F_d = ma$$

[1 mark]

$$a = g - F_d/m$$

[1 mark]

(we will accept either up or down as defined as positive).....

full 2 marks if expression for  $a$  is correct even without the first expression.....

A number of students did not give the final line of this answer, leaving their response as "ma =".

c) If the drag force on the ball is given by  $F_d = \frac{1}{4}\pi r^2 \rho v^2$ , where  $\rho$  is the density of the air,  $r$  is the radius of the ball, and  $v$  is the instantaneous speed of the ball.

Find an expression for the terminal speed of the ball  $v_t$ , in terms of  $m$ ,  $g$ ,  $r$  and  $\rho$ .

[3 marks]

Answer: .....

Terminal velocity implies  $a = 0$  therefore  $F_d = mg$

[1 mark]

$$\frac{\pi}{4} r^2 \rho v_t^2 = mg$$

[1 mark]

(or for any sensible rearrangement such as  $v_t^2 = \frac{4mg}{\pi r^2 \rho}$ )

$$v_t = \frac{2}{r} \sqrt{\frac{mg}{\pi \rho}}$$

[1 mark]

(all marks will be given for a correct answer whether these three steps are taken or not. It must be clear however how the answer has been arrived at.

For example, only 1 mark will be given if the final line is stated without any explanation of  $a=0$  two out of three marks if the answer is given as  $v$  not  $v_t$ .)

Generally well answered: mistakes involved not transposing the drag forces correctly from the question and failing to rearrange correctly.

- d) Calculate the value of the terminal speed of the ball given that it has a mass  $m = 25\text{ g}$ , a radius  $r = 25\text{ cm}$ , and that the density of the air  $\rho = 1.2\text{ kg m}^{-3}$ .

(gravitational field strength =  $9.8\text{ N kg}^{-1}$ )

[2 marks]

Answer: ...  $v_t = \frac{2}{r} \sqrt{\frac{mg}{\pi\rho}} = \frac{2}{25 \times 10^{-2}} \sqrt{\frac{25 \times 9.8 \times 10^{-3}}{3.14 \times 1.2}}$

[1 mark]

$v_t = 2.0(4)\text{ m s}^{-1}$  [answers that had used  $g = 10\text{ ms}^{-2} \rightarrow 2.06$  and no second mark][1 mark]

One mark for correctly converting units from cm and g, one mark for the correct answer.

Correct unit conversion mark is equivalent to an error carried forward mark for an incorrect expression from (c). i.e. if an incorrect expression is calculated and carried forward students can still achieve 1 mark for correctly converting units. If excessive sig figs were given or units were missing 1 mark was deducted (this rule was only applied once for the whole of P1).

The main source of error in this question was incorrect unit conversions and students failing to take the square root on their calculator.

- e) Sketch a graph of the ball's speed against time, labelling the terminal speed of the ball.

In words, relate the acceleration of the ball to the gradient of your speed-time graph.

[4 marks]

Answer:

Correct line shape (graph may be inverted – either sign allowed), which means...

- reaching horizontal line (gradient = 0) and stating acceleration therefore is zero. [1 mark]
- $v_t$  labelled symbolically or numerically... [1 mark]
- Between zero and  $v_t$  the line is curved with the right sign of curvature as shown in sketch above. [1 mark]
- Initial gradient at  $t_0 = g = 9.8\text{ ms}^{-1}$  (just saying "greatest" insufficient) [1 mark]

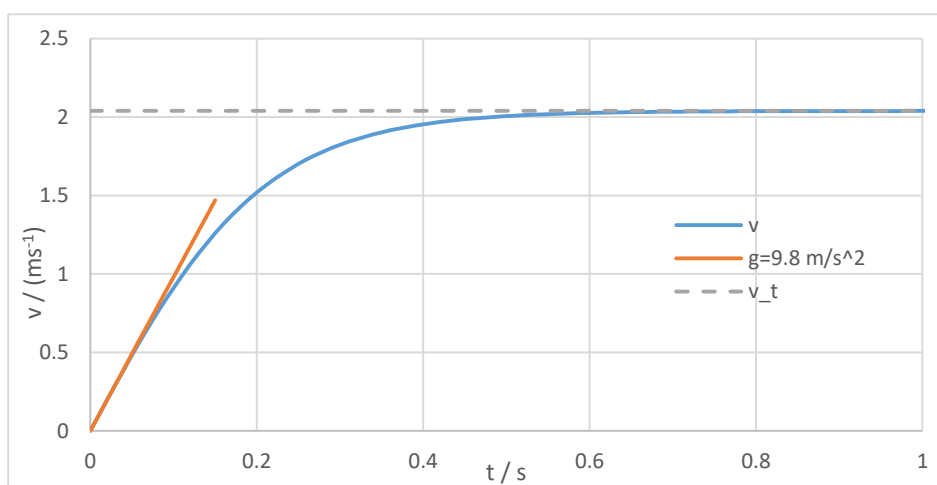

Most students understood the physics of this system and were able to sketch this graph correctly. However, answers were often inconsistent with the description given for part (a). Marks were lost for **not** labelling the terminal velocity as asked (benefit was given here for non-conventional labelling) and marks were lost for indicating that the acceleration was constant for an extended period of time (showing a straight line with constant +ve gradient or curvature for only a small portion of the time before reaching  $v_t$ ).



f) The velocity of the ball varies with height according to the equation

$$\left(\frac{v}{v_t}\right)^2 = \left(1 - 10 \frac{-cy}{m}\right)$$

Where  $m = 25\text{g}$ ,  $c = 0.051\text{ kg m}^{-1}$  and  $y$  is the distance the ball has fallen from the window;  $y = 0$  at the start of the fall.

Calculate the distance that the ball has fallen when its speed is equal to 99% of its terminal speed.

**[3 marks]**

Answer: .....

$$(0.99)^2 = \left(1 - 10 \frac{-cy}{m}\right) \quad \text{[correctly use the 99%]} \quad [1 \text{ mark}]$$

$$\frac{-cy}{m} = \log(1 - 0.99^2) \quad \text{[re-arrange correctly using logs]} \quad [1 \text{ mark}]$$

$$y = 0.83(3) \text{ m (or 83 cm)} \quad \text{[get correct answer]} \quad [1 \text{ mark}]$$

...

*(If students use  $\ln$  rather than  $\log$  they get 2 marks out of 3, as long as everything else is correct) This gives  $y = 1.9(2)m$ .*

*Common mistakes in this question were incorrect manipulation of logs, incorrect unit conversions, rounding too soon, and using numbers too early (i.e. calculating 99% of their value from  $e$  rather than just squaring 0.99). Also, incorrect manipulation of algebra before taking logs. Benefit was given if the correct answer was stated as  $-0.83m$  even though  $y$  should be a positive number.*

**Question P2**

Assume throughout this question that the cells and batteries have no internal resistance.

A light-emitting diode (LED) has the  $I$ - $V$  characteristic graph shown in Fig. 2a:

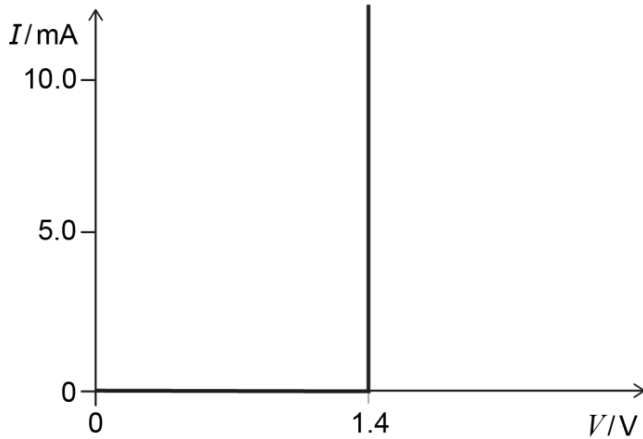

**Figure 2a**

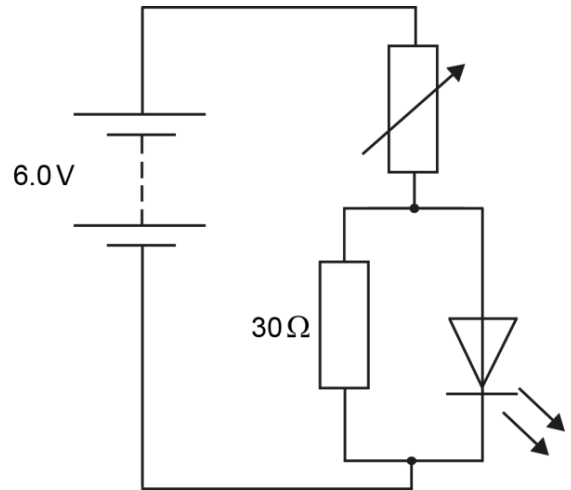

**Figure 2b**

If the potential difference across the LED is less than 1.4 V, no current passes through it. When a current does pass through the LED, the potential difference across it is always 1.4 V.

This LED is connected into the circuit shown in Fig. 2b, and the variable resistor is adjusted until there is a current of 8.0 mA through the LED.

- a) (i)** What is the potential difference across the 30 Ω resistor? **[1 mark]**

Answer: ..... 1.4 V .....

*Components in parallel have the same potential across them. So 1.4 V*

.....

- (ii)** What is the current through the 30 Ω resistor? **[1 mark]**

Answer: .....  $I = \frac{1.4}{30} = 0.047 \text{ A}$  (or 47 mA) .....

*two significant figures are given, and so the answer is expected to be the same. Sometimes 3 or 4 figures were given, and sometimes only 1, but this was not the moment to penalise such infelicities.*

$I = \frac{1.4}{30} = 0.047 \text{ A} = 47 \text{ mA}$  *ecf was allowed if they used 4.6 V to give 153 mA*

b) (i) What is the current through the variable resistor? [1 mark]

Answer: .....(47+8) mA = 55 mA.....(= 0.0547 A) .....

*The two currents in parallel were added to give 47 + 8 = 55 mA. All sorts of rounding errors were catered for here. Ecf was allowed from earlier (153 + 8 = 161 mA)*

*Sometimes there was a very poor approach to considering the sig figs here.*

(ii) What is the potential difference across the variable resistor?  
[1 mark]

Answer: .....6.0 - 1.4 = 4.6 V.....

*6.0 - 1.4 = 4.6 V with no variations allowed here. Some students felt that this should be some combination of the various potentials available.*

(iii) What is the resistance of the variable resistor? [1 mark]

Answer: ..... $R = \frac{4.6}{55 \times 10^{-3}} = 84 \Omega$ .....(= 84.14  $\Omega$ ) .....

*This is 84.(1)  $\Omega$  with a noticeable range of variations with the earlier rounding of the currents. All of these were allowed. Some students calculated a resistance for the LED, which though an artificial construct (175  $\Omega$ ) could, in a convoluted way, be used along with the current and 6 V cell to obtain R.*

c) The following circuit is constructed with a battery of emf 6.0V, two fixed resistors and one variable resistor as shown in Fig. 2c.

*The calculation in part (i) below is designed to get students to see the process of the potential divider with a variable resistor in a parallel arrangement with a simple value. In sketching the subsequent graph, the students' reasoning powers were being tested by considering the effect of  $R_{var}$  without necessarily doing any further calculations. When  $R_{var} = 0$ ,  $R_2$  is shorted and no current will pass through it, so that the full potential of 6 V is across  $R_1$ . Then as  $R_{var}$  is increased, a larger share of the potential is across its parallel arrangement and a smaller share of the potential across the voltmeter. A potential divider circuit in a different context. No mention is made of current in this part and students were fairly successful here. Sometimes the graphs went down to zero, or were entirely linear, but the decreasing trend was generally realised.*

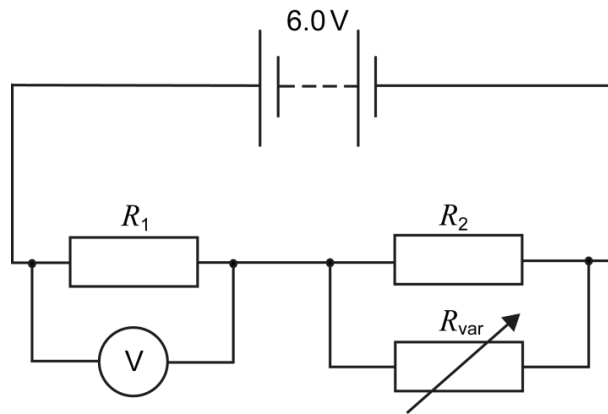

**Figure 2c**

$R_1 = R_2 = 20\ \Omega$ , and  $R_{var}$  can be varied between 0 and  $80\ \Omega$ .

- (i) When  $R_{var}$  is set to  $20\ \Omega$ , what is the voltage shown on the voltmeter?

**[1 mark]**

Answer: .....  $V = \frac{20\ \Omega}{(20+10)\ \Omega} \times 6.0 = 4.0\ \text{V}$  .....

or  $I = \frac{6.0}{(20+10)\ \Omega} = 0.2\ \text{A}$       So       $V = 0.2 \times 20\ \Omega = 4.0\ \text{V}$  .....

- (ii) Sketch a graph of the voltage shown on the voltmeter against  $R_{var}$  for values of  $R_{var}$  between 0 and  $80\ \Omega$ . Plot your result from part (i) on your graph.

**[3 marks]**

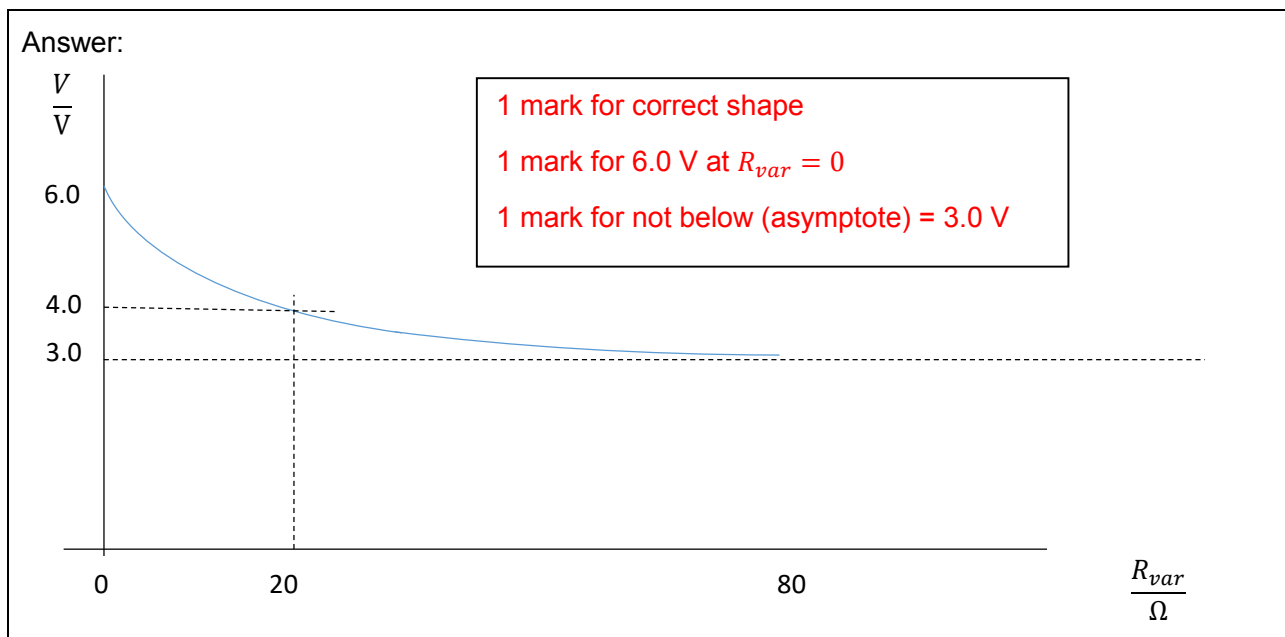

(iii) Calculate the potential difference across the variable resistor, and the power dissipated in the variable resistor, for  $R_{var} = 0.0\Omega$ ,  $5.0\Omega$ ,  $20\Omega$ ,  $50\Omega$  and  $80\Omega$ .

[5 marks]

Answer:

[students are not required to write these formulae down to get the marks – they can calculate the values anyway they like]

$$V_0 = V_i \left( \frac{R_{var}}{20 + 2R_{var}} \right)$$

$$P = \frac{V_0^2}{R_{var}} = \frac{V_i^2 R_{var}}{(20 + 2R_{var})^2}$$

$R_{var}$	V/V	Power / W	
0	0	0	[1 mark]
5.0	$6 \times 5 / 30 = 1$	$1 / 5 = 0.2$	[1 mark]
20	$6 \times 20 / 60 = 2$	$4 / 20 = 0.2$	[1 mark]
50	$6 \times 50 / 120 = 5/2$	$25 / (4 \times 50) = 1/8 = 0.125$	[1 mark]
80	$6 \times 80 / 180 = 8/3$	$64 / (9 \times 80) = 8/90 = 0.09$	[1 mark]

*The power dissipated in the variable resistor was an exercise in being systematic. It might be argued that a table of five results for 5 marks was expecting an all or nothing set of marks. However, this was not the case. Students would get some results but not all. They would sometimes lose track of which resistor they were considering, writing down the potential across the other one, without momentarily checking that this made sense.*

*The initial example of  $R_{var} = 0\Omega$  means that there will be no potential across it and hence no power loss in it. Of course a direct application of  $V^2/R_{var}$  will lead to  $0/0$  but that is taking a formula and not the physics of the situation. Here a moment's thought about  $I^2R$  with a finite current  $I$  through  $R_{var} = 0$  would solve the issue. Again, using  $R_{var} = 20\Omega$  means that there is  $2V$  across  $R_{var}$  as a simple potential divider (with  $20\Omega$  and  $20\Omega$  in parallel), and then  $\frac{V^2}{R_{var}} = 0.2W$ . Having a systematic approach is one of the skills being tested, and those who avoided scribbling a lot of equations and numbers around the page were obviously more successful. At this stage clearly many candidates were very short of time. The graph following could be obtained by sketching for the table, or quite often just from some thinking about the circuit. When  $R_{var} = 0$  no power is dissipated, and when  $R_{var}$  is large, little current flows through it and again little power is dissipated. In between power is dissipated, so the graph has a peak in it. It was pleasing to see students obtaining this without necessarily having produced a table of results. Students will have come across the maximum power from a cell and the fact that a maximum is obtained here may not be a great surprise, although to connect the circumstance is perhaps hindsight here.*

(iv) Using your results from (iii), sketch a labelled graph of the power dissipated in the variable resistor against  $R_{var}$  from 0 to  $80 \Omega$ .

[3 marks]

Answer:

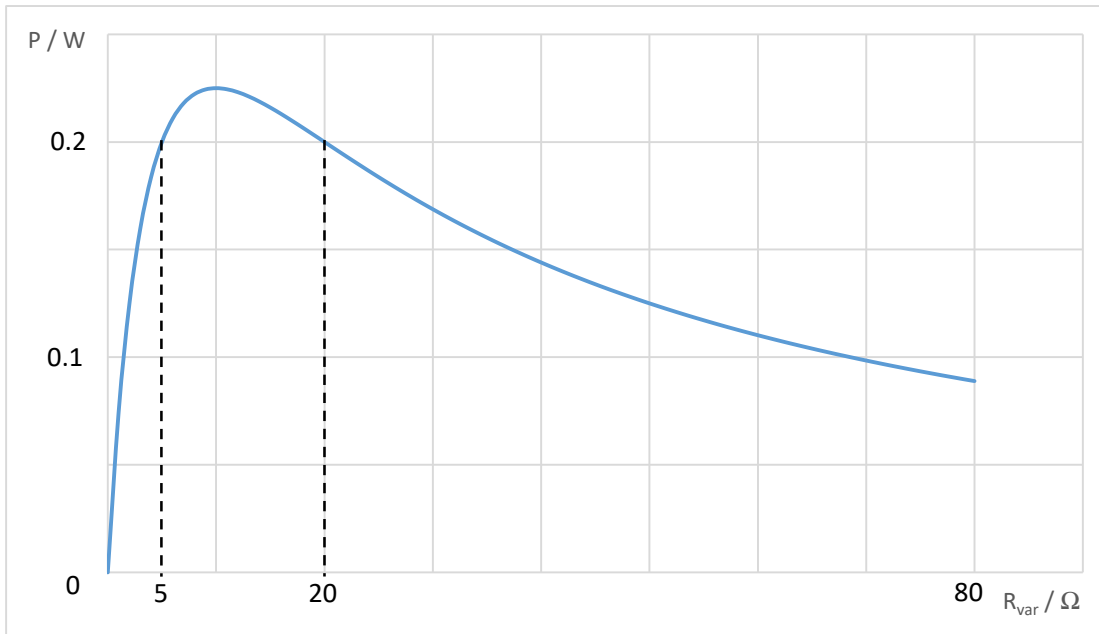

[1 mark] for steep incline

[1 mark] to a maximum between the values of 5 ohms and 20 ohms.

[1 mark] for shallow decline from maximum to correct value at 80 ohms. This should indicate a tending to an asymptote of  $P=0$  W not an asymptote of 0.09 W. i.e. if  $R_{var}$  could tend to infinity the power would tend to zero not to the value calculated for 80 ohms.

[-1 mark if students have not labelled the graph with numbers and/or units]

[1 mark should be given if maximum power is calculated at 10 ohms & 0.225 W but something else is left out – students are not explicitly required to calculate this]

*Not required:*

Differentiating the expression for  $P$ , to set  $\frac{dP}{dR} = 0$

$$P = \frac{V_{var}^2}{R_{var}} = \frac{V_i^2 R_{var}}{(20 + 2R_{var})^2}$$

The max power in  $R_{var}$  is for  $R_{var} = 10 \Omega$  and is  $P_{max} = \frac{9}{40} = 0.225$  W

d) A potentiometer is a three-terminal device often used as a variable resistor by only using two of the three terminals (one end of the resistive track and the sliding contact). An example is shown schematically in Fig. 2d. In a logarithmic potentiometer the resistance varies with the angle of rotation,  $\theta$ .

The graph in Fig. 2e shows how the logarithm of the resistance  $R_{AB}$  varies linearly with angle  $\theta$ .  $\theta$  can vary between  $0^\circ$  and  $270^\circ$ .

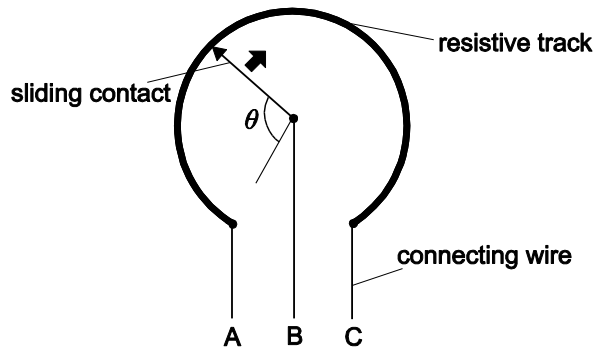

Figure 2d

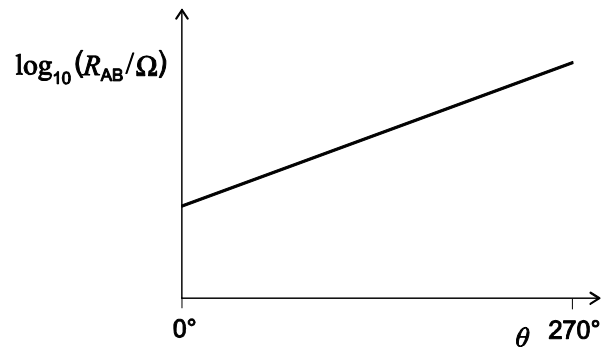

Figure 2e

If the resistance when  $\theta = 0^\circ$  is  $R_{AB} = 1.00 \text{ k}\Omega$ , and when  $\theta = 270^\circ$  is  $R_{AB} = 2.00 \text{ M}\Omega$ , what is the value of  $R_{AB}$  when  $\theta = 110^\circ$ ?

[3 marks]

Answer:

$$\begin{aligned} \log R_{AB} &= k\theta + c \\ \log R_{AB} &= \frac{(\log 2 \times 10^6 - \log 10^3)}{270^\circ} \theta + \log 10^3 \\ &= \frac{\log 2 + 6 - 3}{270^\circ} \theta + 3 = \frac{\log 2 + 3}{270^\circ} \times 110^\circ + 3 \\ &= \frac{11}{27} \log 2 + \frac{38}{9} = 4.345 \\ R_{AB} &= 22.1(2) \text{ k}\Omega \end{aligned}$$

OR Result and some reasoning [3 marks]

OR

$$\log(10^3) = c, \text{ hence } c = 3 \quad [1 \text{ mark}]$$

$$k = \frac{\log R_{AB}(270) - \log R_{AB}(0)}{270 - 0} = \frac{1}{270} \log \left( \frac{R_{AB}(270)}{R_{AB}(0)} \right) = \frac{1}{270} \log \left( \frac{2 \times 10^6}{10^3} \right) =$$

$$0.0122(3) \quad [1 \text{ mark}]$$

mark for finding each constant if constants are incorrect but students identify correct straight line expression ( $\log R_{AB} = k\theta + c$ ) then 1 mark out of 2 given.

$$\text{Hence at } \theta = 110^\circ, R_{AB} = 22 \times 10^3 \Omega = 22.1(2) \text{ k}\Omega \quad [1 \text{ mark}]$$

The last section was an interpolation of a linear graph, with a log scale. Fairly successful for candidates who got this far (if they did not entirely ignore the log scale), although it was decidedly thin on the ground for the 900 plus candidates who attempted this P2 question. Time was the key factor.

## Chemistry

### Question C1

- a) Ketones react with hydroxylamine,  $\text{NH}_2\text{OH}$ , to give oximes. An example of such a reaction involving the ketone propanone is shown below:

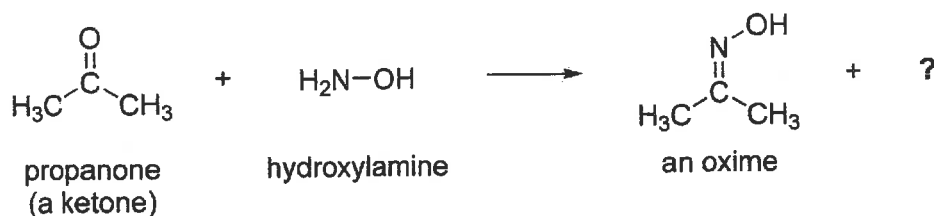

- (i) In addition to the oxime, this reaction produces a second product. Suggest what this molecule might be.

[1 mark]

Answer:  $\text{H}_2\text{O}$  or water [1]

- (ii) Draw the structure of the oxime that you would expect to be formed from the reaction of the ketone cyclohexanone with hydroxylamine.

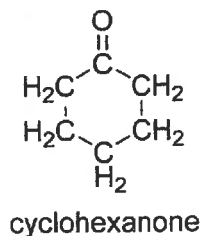

[2 marks]

Answer:

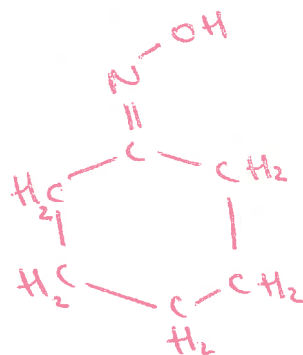

oxime = [1]  
cycle = [1]



- (iii) Oximes are weakly acidic. For the oxime below, explain which hydrogen atom will be the most acidic and draw the structure of the resulting anion  $X^-$ .

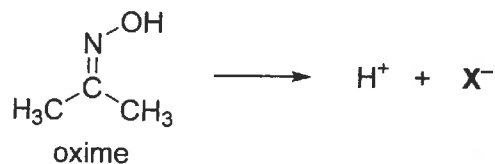

[3 marks]

Answer:

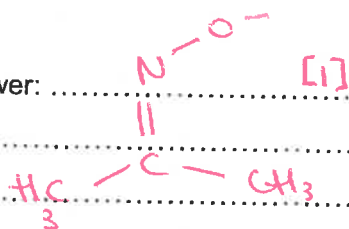

O is electronegative [1]

Stabilises negative charge [1]

- b) Under acidic conditions, oximes undergo the following rearrangement reaction (note carefully that there are two different groups R and R').

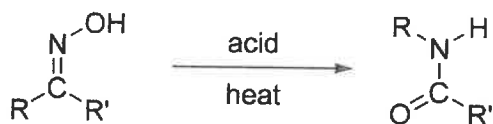

Give the analogous structures into which each of the following oximes rearrange under the same conditions.

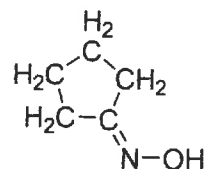
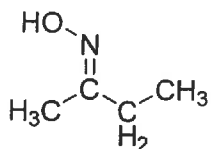
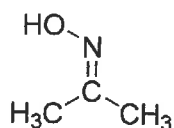

[4 marks]

Answer:

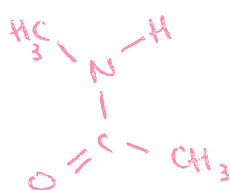

[1]

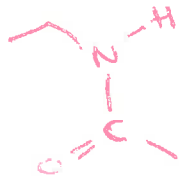

[1]



[1]

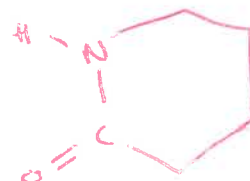

[1]

- c) Dimethylglyoxime reacts with  $\text{Ni}^{2+}$  ions in aqueous solution under mildly basic conditions to give a complex which is an insoluble red precipitate. The reaction involves two molecules of dimethylglyoxime and also results in the production of two  $\text{H}^+$  ions.

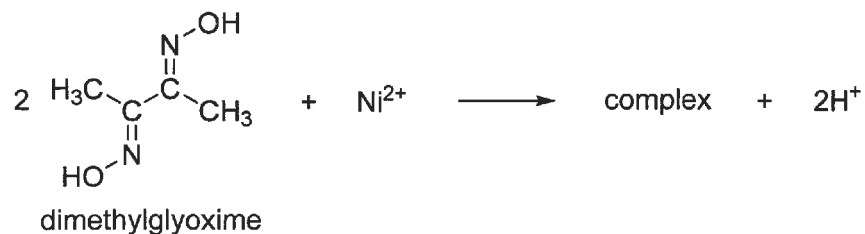

Assuming that the above equation is balanced, determine the **molecular formula** of the complex and its relative molecular mass; a structural formula is **not** required.

(Relative atomic mass data is given in the Periodic Table on page 14.)

[4 marks]

Answer:  $\text{Ni}(\text{C}_4\text{O}_2\text{N}_2\text{H}_7)_2 = \text{NiC}_8\text{O}_4\text{N}_4\text{H}_{14}$  [2]  
 Mass = 288.922 [2]

.....  
 .....  
 .....  
 .....  
 .....  
 .....  
 .....

- d) The reaction between dimethylglyoxime and  $\text{Ni}^{2+}$  ions can be used to determine the nickel content of alloys by weighing the amount of the red precipitate produced from a known mass of a sample of an alloy.

A sample of mass 1.50 g of an alloy was dissolved in dilute acid and an excess of dimethylglyoxime was then added to the resulting solution. The pH was then adjusted to make the solution mildly alkaline, and this resulted in the formation of a red precipitate. The precipitate was carefully filtered off, dried and then weighed. The mass of the dry precipitate was 0.368 g.

Determine the nickel content of the alloy, expressed as a percentage by mass.

[4 marks]

Answer:  $\frac{0.368}{288.922} = 1.2737 \times 10^{-3} \text{ mol}$  [1]

Amount of Ni =  $1.2737 \times 10^{-3} \text{ mol}$  [1]

Mass of Ni = 0.07475 g [1]

% Mass of Ni = 4.98356% [1]

- e) Other metal ions, such as  $\text{Pd}^{2+}$  or  $\text{Pt}^{2+}$ , also react with dimethylglyoxime to give insoluble precipitates. What effect would the presence of palladium in the alloy have on the value of the nickel content determined using the method in part d)?

[2 marks]

Answer: Pd / Pt will precipitate  $\rightarrow$  increase in mass. [1]

Make the Ni (%) look too high = wrong answer [1]

for Ni value.

**Question C2**

- a) Write a balanced chemical equation for the reaction between  $\text{CO}_2(\text{g})$  and  $\text{OH}^-(\text{aq})$ , giving  $\text{CO}_3^{2-}(\text{aq})$  as one of the products.

[1 mark]

Answer:  $\text{CO}_2(\text{g}) + 2\text{OH}^-(\text{aq}) \rightarrow \text{CO}_3^{2-}(\text{aq}) + \text{H}_2\text{O}(\text{l})$  [1]

Accept: no state symbols



↑ but this is incorrect for (b)(ii) and (b)(iii)

- b) An organic molecule is known to contain C, H and O only. A sample of mass 0.100 g is carefully burnt in the presence of excess oxygen. The resulting gases are passed over a desiccant (drying agent), and it is observed that the mass of the desiccant increases by 0.0931 g.

After passing through the desiccant the gases are bubbled through 25.0 cm<sup>3</sup> of a solution of 1.00 mol dm<sup>-3</sup> NaOH. The solution is then titrated against 1.00 mol dm<sup>-3</sup> HCl, and the end point is found to be when 14.7 cm<sup>3</sup> of the acid has been added.

- (i) Calculate the amount in moles of H<sub>2</sub>O produced by the combustion.

[2 marks]

Answer:  $m_{\text{H}_2\text{O}} = 0.0931 \text{ g}$  [1]

$$n_{\text{H}_2\text{O}} = \frac{0.0931 \text{ g}}{18.00 + 2 \times 1.008} = 5.167628774 \times 10^{-3} \text{ mol} \approx 5.17 \times 10^{-3} \text{ mol}$$
 [1]

- (ii) Calculate the amount in moles of CO<sub>2</sub> absorbed by the NaOH solution.

[4 marks]

Answer:  $n_{\text{HCl}} = 14.7 \times 10^{-3} \text{ dm}^3 \times 1.00 \text{ mol dm}^{-3} = 14.7 \times 10^{-3} \text{ mol} \equiv 0.0147 \text{ mol}$  [1]

$n_{\text{OH}^- \text{ titrated}} = n_{\text{HCl}} = 14.7 \times 10^{-3} \text{ mol}$  [1]

$n_{\text{OH}^- \text{ reacted with CO}_2} = (25.0 \times 10^{-3} \text{ dm}^3 \times 1.00 \text{ mol dm}^{-3}) - 14.7 \times 10^{-3} \text{ mol} = 10.3 \times 10^{-3} \text{ mol} \equiv 0.0103 \text{ mol}$  [1]



2     1

$n_{\text{CO}_2} = 10.3 \times 10^{-3} \text{ mol} \times \frac{1}{2} = 5.15 \times 10^{-3} \text{ mol} \equiv 0.00515 \text{ mol}$  [1]

If 1:1 ratio in a), accept e.c.f:  $10.3 \times 10^{-3} \text{ mol}$  [1]

(iii) Hence determine the empirical formula of the organic molecule.

[6 marks]

Answer:  $n_C = n_{CO_2} = 5.15 \times 10^{-3} \text{ mol}$  [1]

$n_H = 2 \times n_{H_2O} = 2 \times 5.1676 \times 10^{-3} \text{ mol} = 10.335 \times 10^{-3} \text{ mol}$  [1]

Mass of O in sample:

$0.100 \text{ g} - (5.15 \times 10^{-3} \text{ mol} \times 12.00 \text{ g mol}^{-1}) - (10.335 \times 10^{-3} \text{ mol} \times 1.008 \text{ g mol}^{-1}) = 0.02778 \text{ g}$  [1]

$\therefore n_O = \frac{0.02778 \text{ g}}{16.00 \text{ g mol}^{-1}} = 1.7364 \times 10^{-3} \text{ mol}$  [1]

$n_C : n_H : n_O = 3 : 6 : 1$  [1]

Empirical formula =  $C_3H_6O$  [1]

c) Determine the oxidation state of the metal atom or atoms in the following species.

(i)  $MnO_4^{2-}$

[1 mark]

Answer:  $-2 - (-2) \times 4 = +6$  [1]

(ii)  $K_2Cr_2O_7$

[2 marks]

Answer:  $K: +1$  [1]

$Cr: (-2 - (-2) \times 7) \div 2 = +6$  [1]

- d) Write a balanced chemical equation in which  $\text{Fe}^{2+}$  is oxidised to  $\text{Fe}^{3+}$  by  $\text{MnO}_4^-$  in an **acidic aqueous solution** and in which the Mn is reduced to a species with oxidation state +2. Your equation must balance for both atoms and charge, and you may **not** use free electrons ( $e^-$ ) to achieve this.

[4 marks]

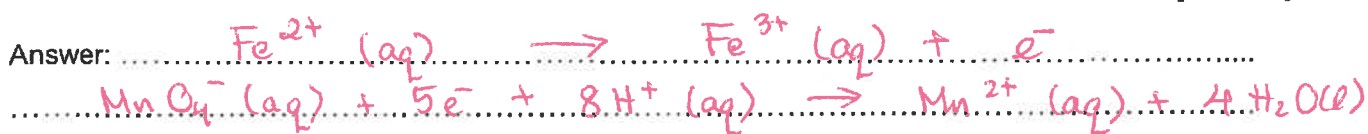

[4] if all correct





## **Biology Admissions Assessment Answers 2018**

### **B1**

- a) Sketch a simple diagram of a eukaryotic cell, and label the locations where DNA transcription and RNA translation take place (2 Marks)

**A. Students should draw a simple diagram, with transcription labelled in the nucleus (1 Mark) and translation on free or attached ribosomes in the cytoplasm (1 Mark)**

- b) When RNA is translated into proteins, it is read in triplets (codons). What proportion of codons might be viewed as redundant in the genetic code (i.e. in excess of the minimum needed to make all amino acids)? (2 Marks)

**A: 44/64 (one Mark for numerator and one Mark for denominator)**

- c) What is an advantage of having more codons in the genetic code than there are amino acids? (2 Marks)

**A: Point mutations may lead to same amino acid (1 Mark), which gives increased fault tolerance (1 Mark).**

- d) A ribosome can translate 18 bases per second. How many seconds would it take to produce a protein that was 299 amino acids long? (2 Marks)

**A: 897/18, or 49.833 (one Mark for 299x3, one Mark for calculation)**

- e) Imagine that an alien organism is found that translates its RNA using pairs of nucleotides instead of triplets. During translation, the alien organism can produce 50 possible amino acids. What is the minimum number of different types of nucleotides that would be needed to produce all of the amino acids? (2 Marks)

**A: 8 ( $8^2 = 64$ , 2 Marks for correct answer)**

- f) Using examples, describe the changes that can occur in DNA sequences and how these can lead to genetic diseases. (10 Marks)

**A: 2 Marks each for explaining the importance of the following, with mention of the effects that they can have:**

**Substitution (change in aas, premature chain termination)**

**Deletion (loss of aas, genes + frameshifts)**

**Insertion (gain in aas, frameshifts)**

**2 Marks for each of two specific examples of diseases (with some detail)**



## **B2**

- a) Describe one benefit and one problem associated with using quadrats in a study like this. (2 Marks)

**A: Benefit: increased speed/lower effort (1 Mark)  
Problem: Sample error (1 Mark)**

- b) Calculate the frequency of occurrence of the species in the quadrats. (1 Mark)

**A. 6/8 (1 Mark)**

- c) Calculate the mean number of plants found per square metre in the quadrats (1 Mark)

**A. 12/32 (1 Mark for mean per quadrat, 1 Mark for mean per metre)**

- d) For the field as a whole, the population grows by 70 individuals per week. How long will the population take to reach an average density of two plants per square metre in the whole field? (2 Marks)

**A. 25 days (1 Mark for calculating final number of plants, 1 Mark for calculating time)**

- e) This invasive plant only produces flowers every 5 years. Why might this occur? (3 Marks)

**A. One Mark each for identifying:  
Importance of synchrony with pollinators  
Importance of asexual reproduction  
Importance of resource build-up  
(or 1 Mark for other sensible ideas)**

- f) Discuss the factors that may affect the spread and photosynthetic rate of the plant. (10 Marks)

**A. 2 Marks for discussing each of the following (up to a maximum of 10):  
Limits to transmission (e.g. vectors for pollen, seeds)  
Limitations on spread from competition (inter-specific)  
Limitations on spread due to reproduction/growth rate  
Limitations on spread do to environmental conditions  
Effects of light intensity on photosynthesis  
Effects of CO<sub>2</sub> levels on photosynthesis  
Effects of temperature on photosynthesis  
+ Any other sensible idea not related to the above**

**To get the full 2 Marks for each topic, students should have a level of specificity in their answers and not just state that a factor “has an effect”. For the photosynthetic element, graphs or detailed descriptions are expected.**